

# 10NDA610

## Very High Output Neodymium MF Transducer

### KeyFeatures

- 103 dB SPL 1W / 1m average sensitivity (AIC on)
- 75 mm (3 in) Interleaved Sandwich Voice coil (ISV)
- 400 W AES power handling
- Neodymium motor assembly
- A.I.C. (Active Impedance Control) technology
- Very shallow profile, 90 mm (3,5 in) total depth
- Humidity resistant cone and plates
- Suitable for high quality, very high SPL midrange frequency reproduction

### Description

The 10NDA610 is a high power, very high output, state-of-the-art midrange transducer for high quality professional use. The high level of sound reproduction is achieved thanks to extensive research by Eighteen Sound engineers, which focused on implementing mid frequencies intelligibility. The 10NDA610 is ideally used as a midrange in both horn and direct radiation, closed or reflex enclosures, as small as 4 liters. The 10NDA610 incorporates an Active Impedance Control (A.I.C.) consisting of an additional coil fixed on the pole piece and connected in parallel to the moving coil. The magnetic field generated by this coil has the following effects: 1) Impedance linearization 2) Acoustic and electric phase linearization 3) Significant increase of sensitivity and total SPL 4) Total harmonic distortion reduction 5) Constant power transfer. The A.I.C. offers substantial advantages to the sound quality by not absorbing the moving coil's electromagnetic energy. The extremely powerful external neodymium magnet assembly assures high flux concentration, low power compression and excellent heat exchange. The levels of force factor and power handling are consequently at a top professional level, with the best power to weight ratio on the market today. The curvilinear cone, made with a high damping wood pulp, has been designed to achieve the best possible linearity within its frequency range. The in-house developed cone treatment acts as humidity repellent and significantly dampens bell mode resonances. The 75mm edge-wound voice coil assembly is wound on a strong fiberglass former to improve force transmission and power handling. A proprietary humidity-block cone treatment makes the transducer suitable for outdoor use in adverse weather conditions. In addition, a special coating applied to both the top and back plates makes the 10NDA610 far more resistant to the corrosive effects of salts and oxidation.

### Models

| Model      | Code       | Information |
|------------|------------|-------------|
| 022108N210 | 022108N210 | 80hm        |

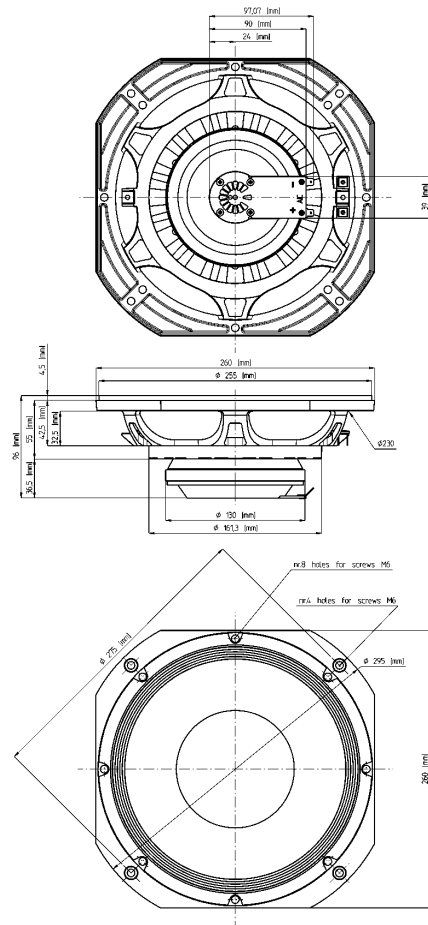

# 10NDA610

## Very High Output Neodymium MF Transducer

### General Specifications

|                               |                               |
|-------------------------------|-------------------------------|
| Nominal Diameter              | 260mm (10 in)                 |
| Rated Impedance               | 8 Ohm                         |
| AES Power                     | 400W                          |
| Program Power                 | 600W                          |
| Peak Power                    | 1200W                         |
| Sensitivity                   | 103dB                         |
| Frequency Range               | 100 - 6100 Hz                 |
| Power Compression @-10dB      | 0,5 dB                        |
| Power Compression @-3dB       | 1,5 dB                        |
| Power Compression @Full Power | 2,1 dB                        |
| Max Recomm. Frequency         | 4000 Hz                       |
| Recomm. Enclosure Volume      | 4 ÷ 15 lt. (0,14 ÷ 0,53 cuft) |
| Minimum Impedance             | 6,5 Ohm at 25°C               |
| Max Peak To Peak Excursion    | 13 mm (0,51 in)               |
| Voice Coil Diameter           | 75 mm (3 in)                  |
| Voice Coil Winding Material   | aluminum                      |
| Suspension                    | Double roll, polycotton       |
| Cone                          | Curvilinear, Paper            |

### Thiele Small Parameters

|                                    |                             |
|------------------------------------|-----------------------------|
| Fs                                 | 89 Hz                       |
| Re                                 | 5,5 Ohm                     |
| Sd                                 | 0,035 sq.mt. (54,25 sq.in.) |
| Qms                                | 7,1                         |
| Qes                                | 0,24                        |
| Qts                                | 0,23                        |
| Vas                                | 18 lt. (0,64 cuft)          |
| Mms                                | 30 gr. (0,07 lb)            |
| BL                                 | 20,3 Tm                     |
| Linear Mathematical Xmax           | ±2,5 mm (± 0,10 in)         |
| Le (1kHz)                          | 0,06 mH                     |
| Ref. Efficiency 1W@1m (half space) | 98 dB                       |

### Mounting information

|                                |  |
|--------------------------------|--|
| Overall diameter               | 260 mm (10,24 in)  |
| N. of mounting holes and bolt  | 4 on diam. 275 mm (4 on 10,83 in) 8 on diam. 244,5 mm (4 on 9,63 in) |
| Mounting holes diameter        | 7,15 mm (0,28 in)  |
| Front mount baffle cutout ø    | 232 mm (9,13 in)   |
| Rear mount baffle cutout ø     | 232 mm (9,13 in)   |
| Total depth                    | 96 mm (3,78 in)  |
| Flange and gasket thickness    | 14,5 mm (0,57 in)  |
| Net weight                     | 3,5 kg (7,7 lb)  |
| Shipping weight                | 3,9 kg (8,58 lb)   |
| CardBoard Packaging dimensions | 275 x 275 x 164 mm(10,83 x 10,83 x 6,46 in)                          |

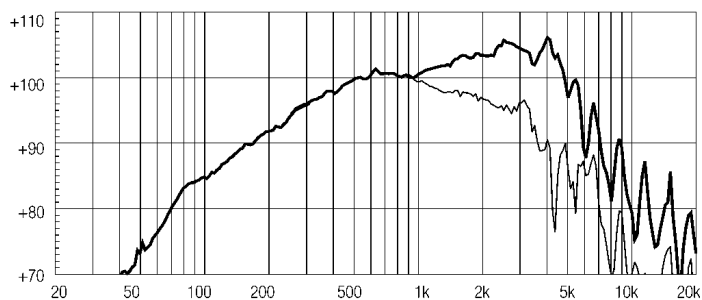

**FREQUENCY RESPONSE CURVE OF 10NDA610 (AIC ON) MADE ON 30 LIT. CLOSED ENCLOSURE IN FREE FIELD (4PI) ENVIRONMENT. ENCLOSURE CLOSES THE REAR OF THE DRIVER. THE THIN LINE REPRESENTS 45 DEG. OFF AXIS FREQUENCY RESPONSE.**

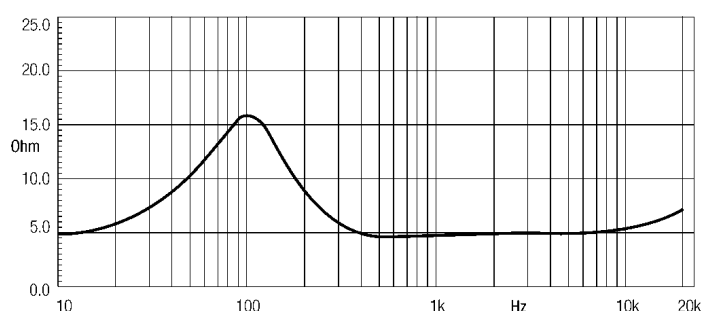

**FREE AIR IMPEDANCE MAGNITUDE CURVE - AIC ON**

### Notes

- 1) AES power is determined according to AES2-1984 (r2003) standard
- 2) Program power rating is measured in a 30 lit closed enclosure, using 100-3000Hz band limited pink noise test signal with 50% duty cycle, applied for 2 hours.
- 3) The peak power rating represents the maximum permitted instantaneous peak power level over a maximum period of 10ms which will be withstood by the loudspeaker without damage.
- 4) Sensitivity represents the averaged value of acoustic output as measured on the forward central axis of cone, at distance 1m from the baffle panel, when connected to 2.83V sine wave test signal swept between 500Hz and 2500Hz with the test specimen mounted in the same enclosure as given for (1) above.
- 5) Frequency range is given as the band of frequencies delineated by the lower and upper limits where the output level drops by 10 dB below the rated sensitivity in half space environment.
- 6) Power compression represents the loss of sensitivity for the specified power, measured from 100-1000 Hz, after a 5 min pink noise preconditioning test at the specified power.
- 7) Linear Math. Xmax is calculated as  $(Hvc-Hg)/2 + Hg/4$  where Hvc is the coil depth and Hg is the gap depth.