

15LW1401

Extended LF Ferrite Transducer

KeyFeatures

- 98 dB SPL 1W / 1m average sensitivity
- 100 mm (4 in) Interleaved Sandwich Voice coil (ISV)
- 1000 W AES power handling
- Carbon fiber reinforced cellulose cone
- Double Silicon Spider (DSS) for improved excursion control and linearity
- Improved heat dissipation via unique basket design
- Weather protected cone and plates for outdoor usage
- Suitable for low bass or subwoofer applications

Description

The 15LW1401 is a low frequency loudspeaker which sets a industry standard in 15" (380 mm) high performance transducers. The transducer has been designed for use as a low bass or sub-woofer component in either a more compact reflex, bandpass or horn loaded configuration. It provides clean, linear, undistorted low frequency reproduction at very high power levels, as part of a high power fullrange system. In its reflex configuration, it can be used in extremely compact enclosures, (65 - 130 lt) which is ideal for touring applications, including indoor and outdoor concert reinforcement systems. The high excursion capabilities of the surround and suspension system, in conjunction with the Eighteen Sound Double Silicon Spider (DSS), enable the 15LW1401 to achieve high levels of linear travel and maintain full control of the moving mass. The carbon fiber reinforced, straight-sided ribbed cone assures smooth response and exceptional strength, with maximum reliability under high mechanical stress. The 100 mm Ø copper voice coil employs the Interleaved Sandwich Voice coil (ISV) technology, in which a high strength fibreglas former carries windings on both the outer and inner surfaces to achieve a mass balanced coil. The weight of the windings are evenly distributed, providing a uniform motive drive. This, in conjunction with the use of state-of-the-art high temperature resin adhesives, results in an extremely linear motor assembly. The already low distortion and sound quality of this loudspeaker has been further improved by the Double Demodulation Rings (DDR) designed to dramatically reduce the intermodulation and harmonic distortion whilst improving the transient response. Excellent heat dissipation has been achieved by incorporating air channels between the basket and the top plate of the magnet. Further ventilation is provided using air vents in the back plate that direct air into the lower part of the voice coil gap. Maximum flux concentration and force factor is assured by the unique shape and design of the top and back plates, researched and designed using Magnetic Flux FEA CAD resource. The 15LW1401's ability to perform properly under inclement weather conditions has been achieved using an exclusive cone treatment improving pulp strength, which gives water repellent properties to both sides of the cone. In addition, a special treatment has been applied to both the top and back plates that is far more resistant to the corrosive effects of salts and oxidization than any other in use today.

Models

Model	Code	Information
0221583120	0221583120	8 Ohm
0221543120	0221543120	4 Ohm

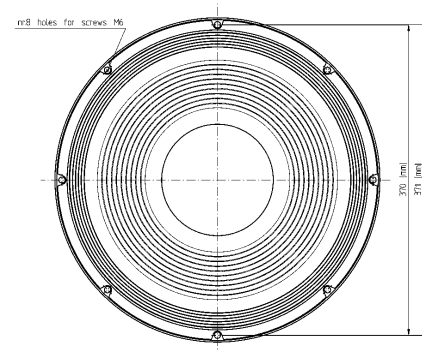
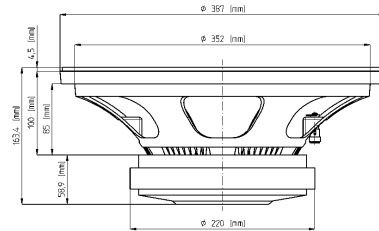

15LW1401

Extended LF Ferrite Transducer

General Specifications

Nominal Diameter	380 mm (15 in)
Rated Impedance	8 Ohm
AES Power	1000 W
Program Power	1400 W
Peak Power	7000 W
Sensitivity	98 dB
Frequency Range	40 ÷ 2400 Hz
Power Compression @-10dB	0,8 dB
Power Compression @-3dB	2,1 dB
Power Compression @Full Power	3,0 dB
Max Recomm. Frequency	800 Hz
Recomm. Enclosure Volume	70 ÷ 150 lt. (2,47 ÷ 5,30 cuft)
Minimum Impedance	6,7 Ohm at 25°C
Max Peak To Peak Excursion	38 mm (1,53 in)
Voice Coil Diameter	100 mm (4 in)
Voice Coil Winding Material	copper
Suspension	Triple roll, Polycotton
Cone	Straight ribbed, Paper

Thiele Small Parameters

Fs	42 Hz
Re	5 Ohm
Sd	0,090 sq.mt. (139,5 sq.in.)
Qms	5,36
Qes	0,28
Qts	0,27
Vas	131 lt. (4,63 cuft)
Mms	125 gr. (0,28 lb)
BL	24,2 Tm
Linear Mathematical Xmax	± 9 mm (±0,35 in)
Le (1kHz)	2,15 mH
Ref. Efficiency 1W@1m (half space)	97,4 dB

Mounting information

Overall diameter	387 mm (15,23 in)
N. of mounting holes and bolt	8
Mounting holes diameter	7,15 mm (0,28 in)
Bolt circle diameter	370 - 371 mm (14,55 - 14,6 in)
Front mount baffle cutout ø	353 mm (13,90 in)
Rear mount baffle cutout ø	357 mm (14,06 in)
Total depth	163,4 mm (6,43 in)
Flange and gasket thickness	19,5 mm (0,76 in)
Net weight	12,4 kg (27,37 lb)
Shipping weight	13,4 kg (29,58 lb)
CardBoard Packaging dimensions	405 x 405 x 214 mm (15,94 x 15,94 x 8,43 in)

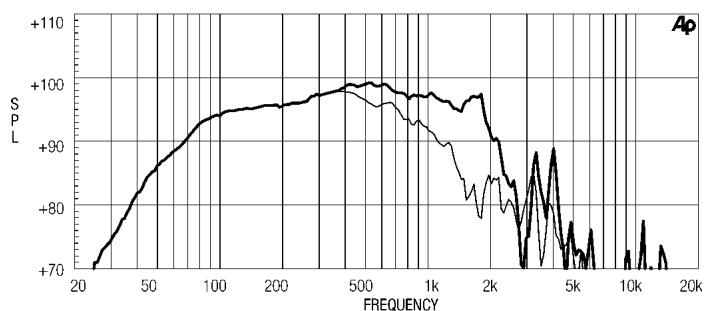

FREQUENCY RESPONSE CURVE OF 15LW1401 MADE ON 125 LIT. ENCLOSURE TUNED 50HZ IN FREE FIELD (4PI) ENVIRONMENT. ENCLOSURE CLOSES THE REAR OF THE DRIVER. THE THIN LINE REPRESENTS 45 DEG. OFF AXIS FREQUENCY RESPONSE

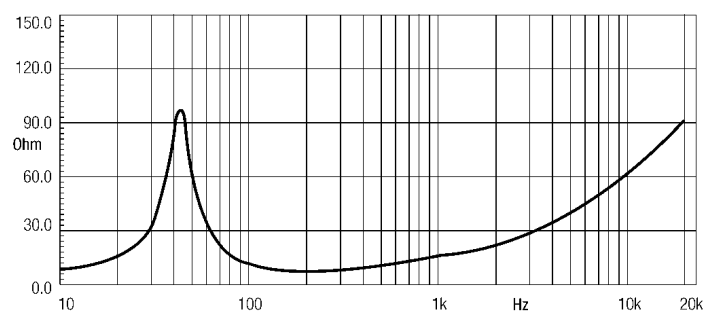

FREE AIR IMPEDANCE MAGNITUDE CURVE

Notes

- 1) AES power is determined according to AES2-1984 (r2003) standard
- 2) Program power rating is measured in 125 lit enclosure tuned 50Hz using a 40 - 400Hz band limited pink noise test signal with 50% duty cycle, applied for 2 hours.
- 3) The peak power rating represents the maximum permitted instantaneous peak power level over a maximum period of 10ms which will be withstood by the loudspeaker without damage.
- 4) Sensitivity represents the averaged value of acoustic output as measured on the forward central axis of cone, at distance 1m from the baffle panel, when connected to 2,83V sine wave test signal swept between 100Hz and 500Hz with the test specimen mounted in the same enclosure as given for (1) above.
- 5) Frequency range is given as the band of frequencies delineated by the lower and upper limits where the output level drops by 10 dB below the rated sensitivity in half space environment.
- 6) Power compression represents the loss of sensitivity for the specified power, measured from 50-500 Hz, after a 5 min pink noise preconditioning test at the specified power.
- 7) Linear Mat. Xmax is calculated as