

15ND830

LF Neodymium Transducer

KeyFeatures

- 98 dB SPL 1W / 1m average sensitivity
- 75 mm (3 in) edgewound voice coil (ISV)
- 450 W AES power handling
- Neodymium magnet assembly
- Weather protected cone for outdoor usage
- Ideal for compact reflex subwoofer and reflex multiway systems

Description

The 15ND830 is a high power, high output, low frequency woofer meeting the most stringent requirements in high quality professional transducers. Thanks to its versatility, the 15ND830 can be used in 2-way compact reflex enclosures and reflex / band pass subwoofers. The neodymium magnet assembly assures high flux concentration, low power compression and excellent heat exchange, since the external magnet configuration is considerably more efficient than traditional under-pole magnet topology. This results in high levels of force factor and power handling with an optimum power to weight ratio. The direct contact between the heat sink and basket, together with the magnetic structure, represents a fundamental improvement in thermal connection and heat dissipation. Hence, power handling capabilities are increased and power compression lowered. The deep profile curvilinear cone, created from a special high strength wood pulp, has been designed to achieve the best possible linearity within its frequency range. The cone surround made from a linen material is highly resistant to aging and fatigue. The in-house developed cone treatment is fully water repellent and also gives a significant degree of rigidity to the cone. The 75mm Interleaved Sandwich Voice coil (ISV) assembly is wound on a strong fibreglas former which improves force transmission and thermal power handling. A special coating applied to both the top and back plates makes the 15ND830 far more resistant to the corrosive effects of salts and oxidization.

Models

Model	Code	Information
022158N210	022158N210	8 Ohm
022154N210	022154N210	4 Ohm

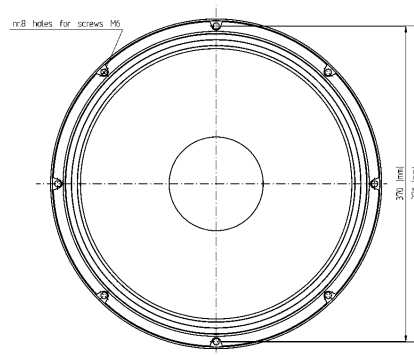
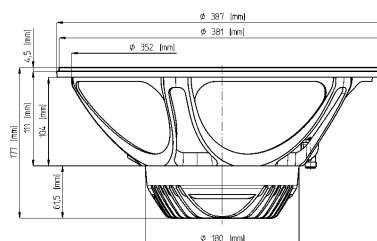

15ND830

LF Neodymium Transducer

General Specifications

Nominal Diameter	380mm (15 in)
Rated Impedance	8 Ohm
AES Power	450W
Program Power	700W
Peak Power	1500W
Sensitivity	98dB
Frequency Range	38 ÷ 5000 Hz
Power Compression @-10dB	0,5 dB
Power Compression @-3dB	2,0 dB
Power Compression @Full Power	3,0 dB
Max Recomm. Frequency	2000 Hz
Recomm. Enclosure Volume	80 ÷ 140 lt. (2,83 ÷ 4,95 cuft)
Minimum Impedance	6,7 Ohm at 25°C
Max Peak To Peak Excursion	33 mm (1,3 in)
Voice Coil Diameter	75 mm (3 in)
Voice Coil Winding Material	aluminum
Suspension	M-roll, Polycotton
Cone	Curvilinear, Paper

Thiele Small Parameters

Fs	39 Hz
Re	5,7 Ohm
Sd	0,085 sq.mt. (131,75 sq. in.)
Qms	3,9
Qes	0,35
Qts	0,32
Vas	213 lt. (7,5 cuft)
Mms	80 gr. (0,18 lb)
BL	18 Tm
Linear Mathematical Xmax	± 6,5 mm (± 0,26 in)
Le (1kHz)	1,54 mH
Ref. Efficiency 1W@1m (half space)	97,5 dB

Mounting information

Overall diameter	387 mm (15,24 in)
N. of mounting holes and bolt	8
Mounting holes diameter	7,15 mm (0,28 in)
Bolt circle diameter	370-371 mm (14,55-14,6 in)
Front mount baffle cutout ø	353 mm (13,9 in)
Rear mount baffle cutout ø	357 mm (14,06 in)
Total depth	177 mm (7,01 in)
Flange and gasket thickness	11,5 mm (0,45 in)
Net weight	4,1 kg (8,05 lb)
Shipping weight	4,8 kg (10,6 lb)
CardBoard Packaging dimensions	405 x 405 x 214 mm (15,94 x 15,94 x 8,43 in)

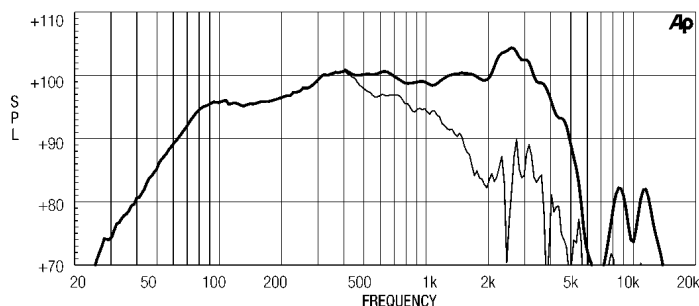

FREQUENCY RESPONSE CURVE OF 15ND830 MADE ON 125 LIT. ENCLOSURE TUNED 50HZ IN FREE FIELD (4PI) ENVIRONMENT. ENCLOSURE CLOSES THE REAR OF THE DRIVER. THE THIN LINE REPRESENTS 45 DEG. OFF AXIS FREQUENCY RESPONSE

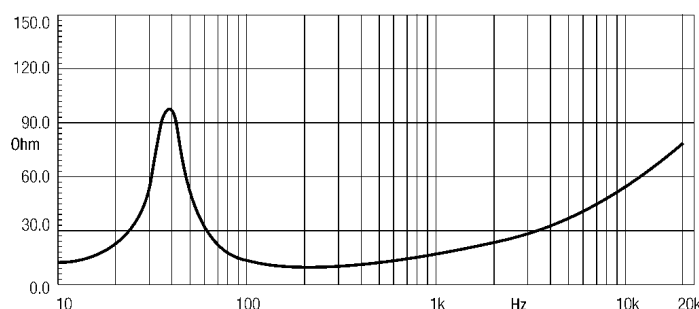

FREE AIR IMPEDANCE MAGNITUDE CURVE

Notes

- 1) AES power is determined according to AES2-1984 (r2003) standard
- 2) Program power rating is measured in 125 lt enclosure tuned at 50Hz using a 40-400Hz band limited pink noise test signal with 50% duty cycle, applied for 2 hours.
- 3) The peak power rating represents the maximum permitted instantaneous peak power level over a maximum period of 10ms which will be withstood by the loudspeaker without damage.
- 4) Sensitivity represents the averaged value of acoustic output as measured on the forward central axis of cone, at distance 1m from the baffle panel, when connected to 2,83 V sine wave test signal swept between 100Hz and 500Hz with the test specimen mounted in the same enclosure as given for (1) above.
- 5) Frequency range is given as the band of frequencies delineated by the lower and upper limits where the output level drops by 10 dB below the rated sensitivity in half space environment.
- 6) Power compression represents the loss of sensitivity for the specified power, measured from 50-500 Hz, after a 5 min pink noise preconditioning test at the specified power.
- 7) Linear Math. Xmax is calculated as $(Hvc-Hg)/2 + Hg/4$ where Hvc is the coil depth and Hg is the gap depth.