

## C173-6-096E

Bass - midrange driver

DOMEMATERIAL: CERAMIC  
APPLICATION: BASS - MIDRANGE  
NOMINAL DIAMETER: 173 mm  
SENSITIVITY: 92.5 dB

### MAIN FEATURES :

- SPECIAL DOME CUTOUTS
- UNDERHUNG MOTOR DESIGN
- 55 MM TITANIUM VC FORMER
- SOFT RUBBER SURROUND
- VENTED VC, POLE PIECE & SPIDER
- 40 HZ - 3 KHZ IN VENTED BOX

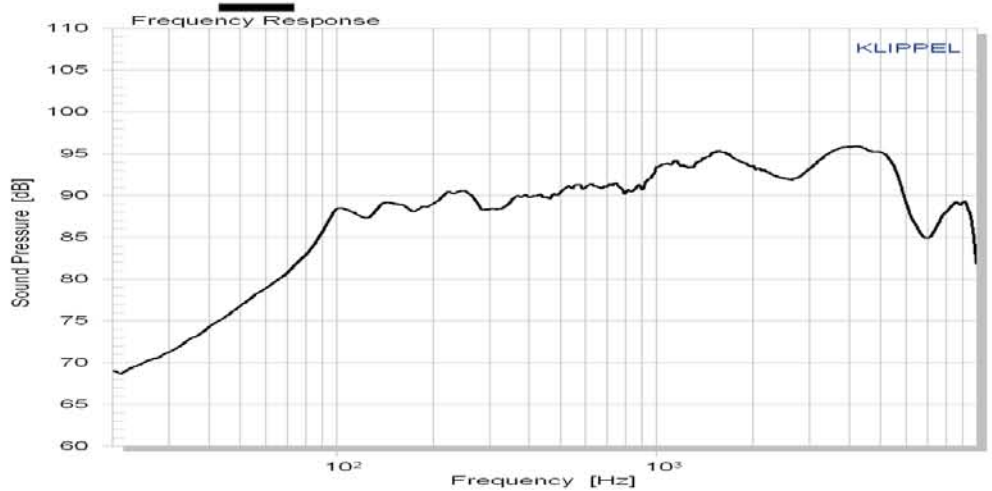

The **C173 – 6 – 096E** is a 6.5 inch bass-midrange driver with ultra hard ceramic dome.

Anti - resonant **cutout fills** in the ceramic dome provide for damping of the 6 kHz dome resonance.

A **FEA optimized** underhung motor design with 55 mm titanium voice coil former guarantees very low energy storage and good heat transfer. Its **high force factor** leads to outstanding transient response for more realistic reproduction.

The low loss rubber surround and a **thin fabric spider** center the moving parts with high linearity.

For this amazing bass-midrange driver, we recommend an application from 40 Hz – 3000 Hz.

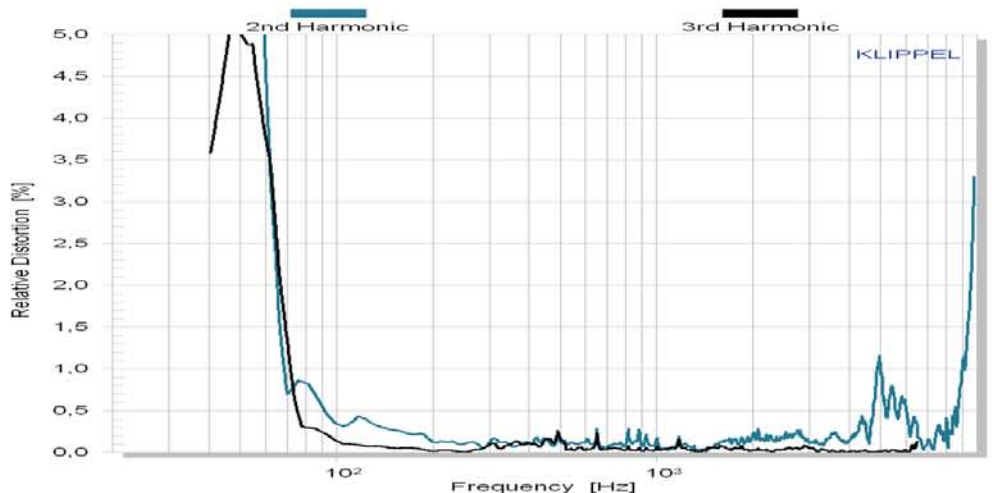
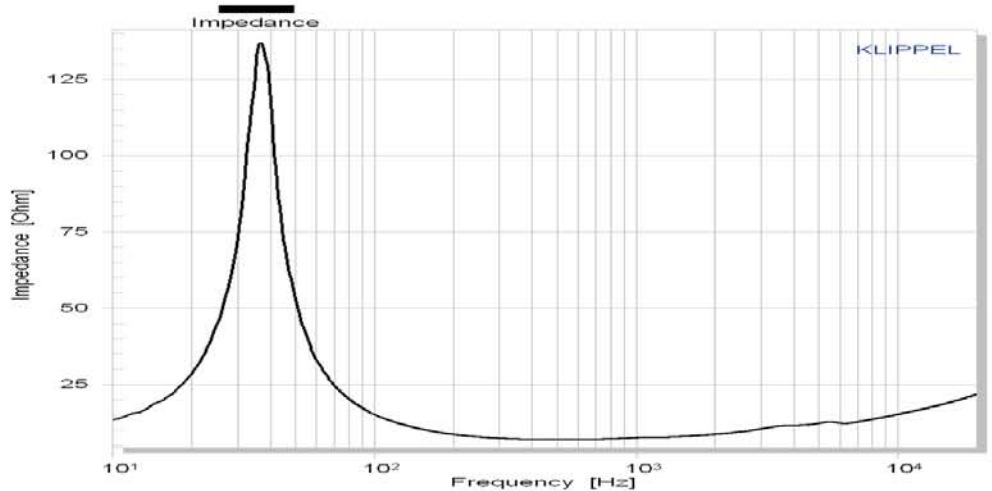

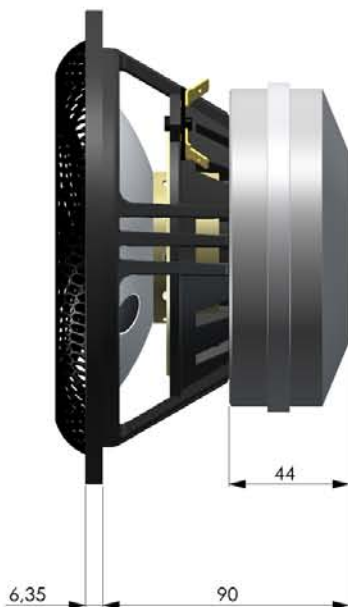

**C173-6-096E**  
Bass-midrange driver

Mechanical data		
Overall diameter	173	mm
Cutout diameter	145.6	mm
Frontplate depth	6.35	mm
Overall depth	96.35	mm
Motor assembly diameter	120	mm
Motor assembly depth	44	mm
Screw fitting	DIN 7984, 4mm	
Terminal	+ : 6.3 x 0.8 / - : 4.8 x 0.8	mm
Shipping weight / net weight	3.76 / 3.44	kg
Shipping size	210 / 140 / 210	mm

Thiele/Small Parameters			
Sensitivity (2.83V / 1m)	Lp	92.5*	dB
DC-resistance	Re	6.61	Ohm
Resonance frequency	Fs	36	Hz
Equivalent volume of air	Vas	29.8	L
Mechanical Q	Qms	4.07	
Electrical Q	Qes	0.18	
Total Q	Qts	0.22	
Effective piston area	Sd	130	cm <sup>2</sup>
Moving mass	Mms	15.5	g
Suspension compliance	Cms	1.23	mm/N
Mechanical resistance	Rms	0.87	kg x s

Voice Coil data			
Power handling	P	120*	Watt
Linear excursion	Xmax	+/- 5	mm
Voice coil diameter		55	mm
Voice coil former material		Ti	
Voice coil material		Cu	
Voice coil inductance	Le	0.20	mH
Force factor	Bl	11.5	N/A
Motor type		Underhung	
Ferrofluid filling		no	

\* Please refer to [www.accuton.com](http://www.accuton.com) for exact measurement conditions and further information.

All rights reserved - All data with reservation and subject to change.

Thiel & Partner GmbH Kantstrasse 1 50259 Pulheim T +49 (0) 2238 / 475475 a.bankewitz@accuton.com