

AUDAX

LA PASSION DU HAUT-PARLEUR

PR170M0

MIDRANGE

100782R

6 1/2" - PAPER CONE DRIVER - 170 mm**PROFESSIONAL LINE**

High power handling capacity - 100 W (IEC)
 Very high efficiency - 100 dB
 Ultra stiff die cast chassis
 Treated flat foam surround
 Special paper cone
 Kapton voice coil former (40 mm Ø)
 Flat aluminium wire
 Gold plated terminals

Puissance admissible élevée - 100 W (CEI)
 Très haut rendement - 100 dB
 Châssis moulé ultra rigide
 Suspension plane mousse traitée
 Cône papier spécifique
 Bobine sur support Kapton (Ø 40 mm)
 Fil plat aluminium sur chant
 Connectique plaquée or

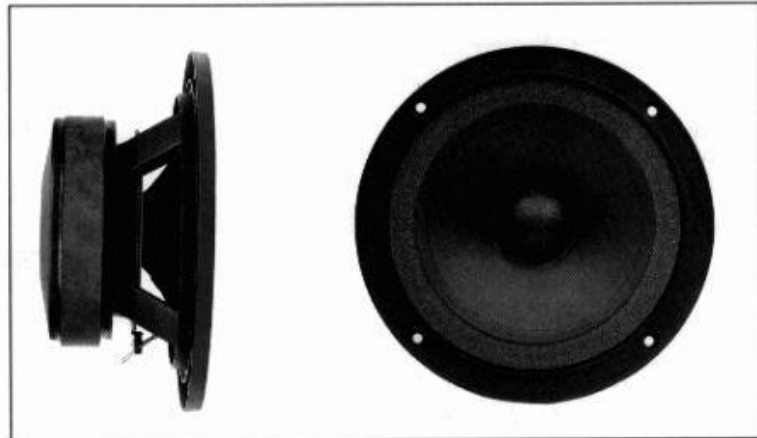

This midrange driver has been specifically designed for high quality professional sound reinforcement systems. Its efficiency and power handling capacity are exceptional for a direct radiation transducer in its category - 100 dB - 100 W due to edgewound flat aluminium wire onto fiberglass reinforced Kapton former. The flat foam suspension is coated with a visco-elastic compound in order to minimize the standing waves and cone break up. It is ideally suited to cover the frequency range from 500 Hz to 8 kHz. This driver is worldwide recognized as the reference in prestigious professional applications. A crossover design is suggested in Fig. 1 and corresponding chart for matching this driver with a woofer in our line is provided. Recommended crossover point : 600 Hz at 18 dB/octave.

Ce haut-parleur médium est spécialement étudié pour les sonorisations professionnelles de grande qualité. Son rendement et sa tenue en puissance sont exceptionnels pour un transducteur de cette catégorie. 100 dB - 100 W grâce à une bobine en fil plat d'aluminium sur chant et son support Kapton renforcé fibre de verre. La suspension plane en mousse traitée par un matériau visco-élastique minimise les ondes stationnaires et contrôle les modes parasites du cône. Son domaine d'utilisation privilégié se situe de 500 Hz à 8 kHz. C'est un haut-parleur reconnu dans le monde entier pour les utilisations professionnelles les plus prestigieuses. Fréquence de coupure recommandée : 600 Hz à 18 dB/octave. Un schéma de filtre passe-bas est proposé (Fig 1) pour un raccordement optimisé aux woofers de notre série.

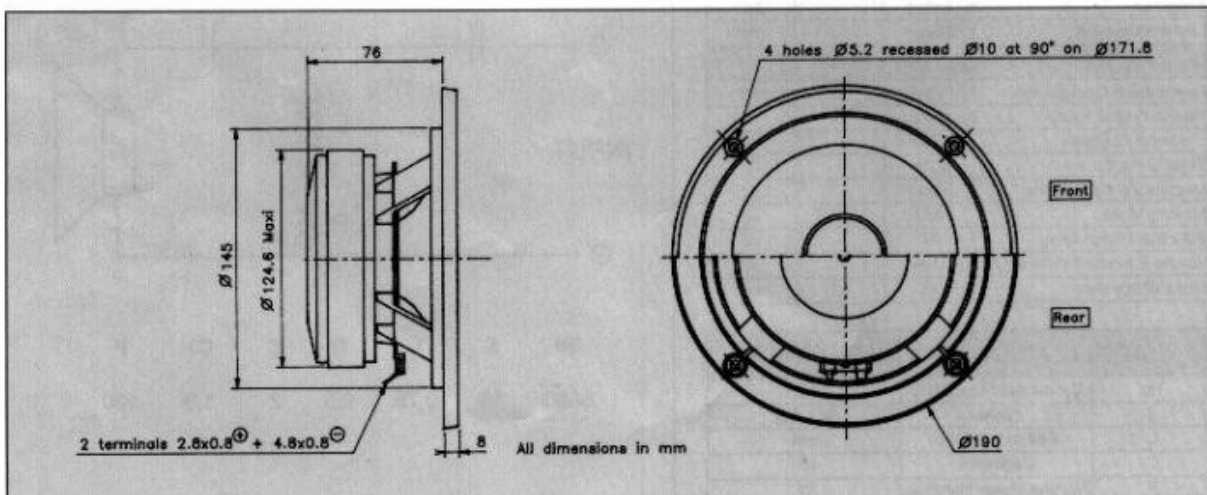

RESPONSE CURVE
refer to page 16

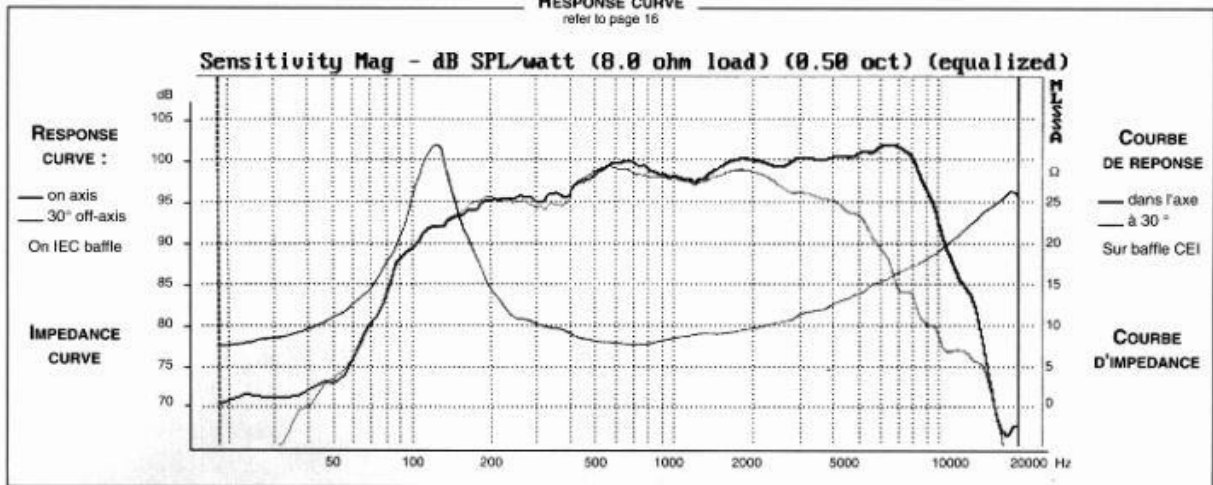

SPECIFICATIONS

Technical Characteristics	Symbol	Value	Units
PRIMARY APPLICATION			
Nominal Impedance	Z	8	Ω
Resonance Frequency	Fs	117	Hz
Nominal Power Handling	P	100	W
Sensitivity	E	100	dB
VOICE COIL			
Voice coil diameter	∅	40	mm
Minimum Impedance	Zmin	6,5	Ω
DC Resistance	Re	6,2	Ω
Voice Coil Inductance	Lbm	0,73	mH
Voice coil Length	h	7	mm
Former	-	Kapton	-
Number of layers	n	1	-
MAGNET			
Magnet dimensions	∅ x h	120 x 20	mm
Magnet weight	m	0,88	kg
Flux density	B	1,4	T
Force factor	BL	8,24	NA ⁻¹
Height of magnetic gap	He	6	mm
Stray flux	Fmag	-	Am ⁻¹
Linear excursion	Xmax	±0,5	mm
PARAMETERS			
Suspension Compliance	Cms	0,2.10 ⁻³	mN ⁻¹
Mechanical Q Factor	Qms	3,16	-
Electrical Q Factor	Qes	0,61	-
Total Q Factor	Qts	0,51	-
Mechanical Resistance	Rms	2,1	kg s ⁻¹
Moving Mass	Mms	9,17.10 ⁻³	kg
Effective Piston Area	S	1,39.10 ²	m ²
Volume Equivalent of Air at Cas	Vas	5,52.10 ¹	m ³
Mass of speaker	M	2,5	kg

APPLICATION PARAMETERS

Fc	Crossover Frequency	Hz
S	Slope	dB / Oct.
L	Self-inductance	mH
C	Capacitor	μF
P	Nominal Power Handling	W

IMPULSE RESPONSE

WATERFALL
refer to page 16

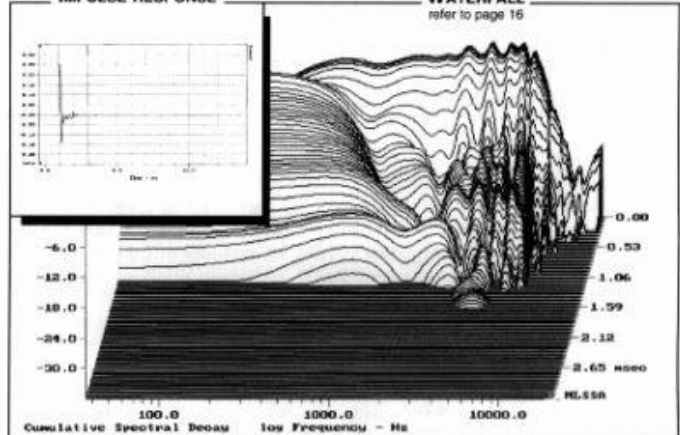

SUGGESTED APPLICATIONS
refer to page 8 to 13

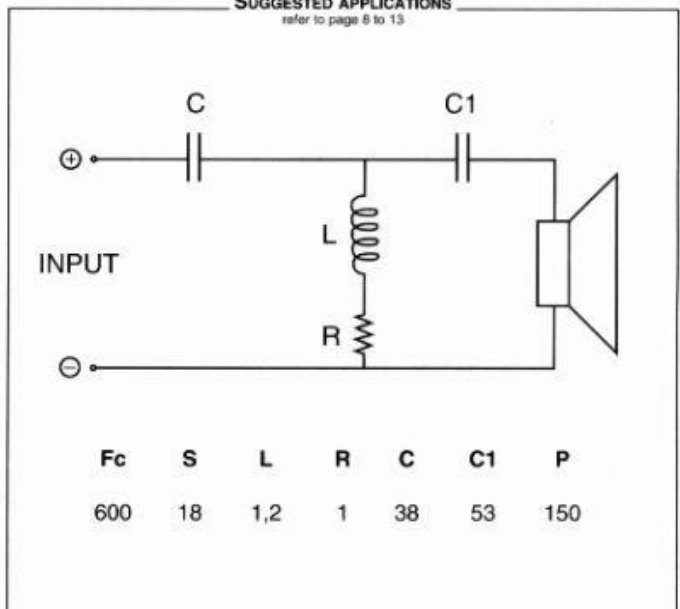

Please refer to method of measurement and measurement conditions pages 15 to 19.
 Audax may, without prior notification modify the specifications on its products further to research and development requirements.