

**AUDAX**

LA PASSION DU HAUT-PARLEUR

**PR170X0**

MIDRANGE

100893B

**6 1/2" - TPX CONE DRIVER - 170 mm****PROFESSIONAL LINE**

TPX cone  
 Very high efficiency - 101 dB  
 Ultra stiff die cast chassis  
 Treated flat foam suspension  
 Kapton voice coil former (40 mm Ø)  
 Flat aluminium wire  
 Gold plated terminals  
 Solid aluminium phase plug

Cône TPX  
 Très haut rendement - 101 dB  
 Châssis moulé ultra rigide  
 Suspension plane mousse traitée  
 Bobine sur support Kapton (Ø 40 mm)  
 Fil plat aluminium sur chant  
 Connectique plaquée or  
 Ogive aluminium massif

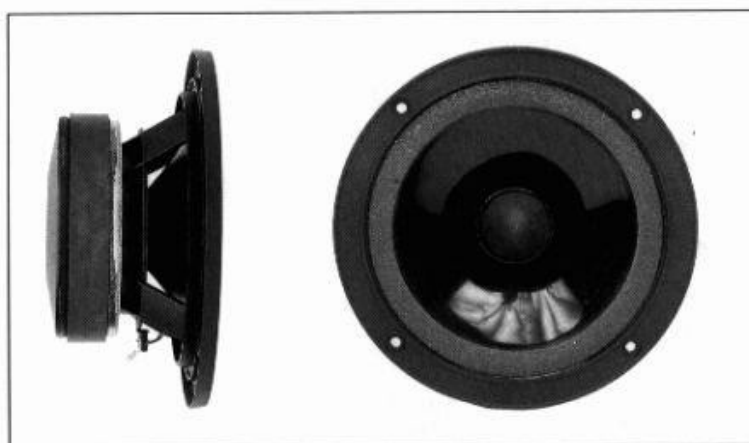

This midrange driver has been specifically designed for high fidelity professional sound reinforcement systems. Its efficiency and power handling capacity are exceptional for a direct radiation transducer of its category - 101 dB - 100 W due to an edgewound flat aluminium voice coil mounted on a fiberglass reinforced Kapton former. The flat foam suspension is coated with a visco-elastic compound in order to minimize the standing waves and cone break-up. It is ideally suited to cover the frequency range from 500 Hz to 8 kHz. TPX featuring high internal damping and high sound velocity, provides this driver with an exceptional musical balance coupled with perfect neutrality. A crossover design is suggested in Fig. 1 and corresponding chart for matching this driver with a woofer in our line is provided. Recommended crossover point : 600 Hz at 18 dB/octave.

Ce haut-parleur médium est spécialement étudié pour les sonorisations professionnelles de qualité haute fidélité. Son rendement et sa tenue en puissance sont exceptionnels pour une transducteur de cette catégorie. 101 dB - 100 W grâce à une bobine en fil plat d'aluminium sur chant et son support Kapton renforcé fibre de verre. La suspension plane en mousse traitée par un matériau visco-élastique minimise les ondes stationnaires et contrôle les modes parasites du cône. Son domaine d'utilisation privilégié se situe de 500 Hz à 8 kHz. Le TPX, matériau à haut coefficient d'amortissement interne et à grande vitesse de propagation du son, confère à ce haut parleur une musicalité exceptionnelle d'une parfaite neutralité. Fréquence de coupure recommandée : 600 Hz à 18 dB/octave. Un schéma de filtre passe-bas est proposé (Fig 1) pour un raccordement optimisé aux woofers de notre série.

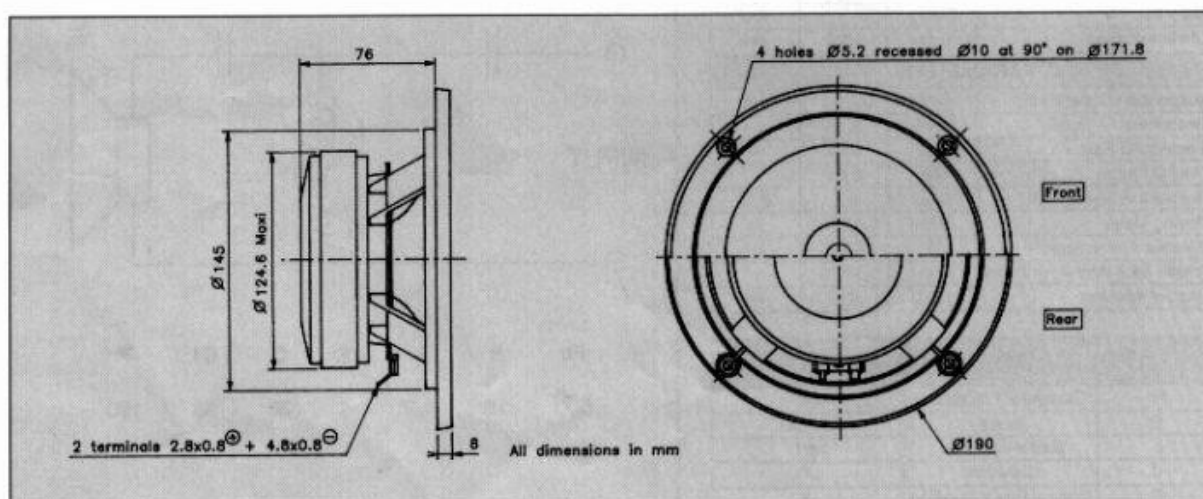

PR170X0 M08XNV3712

100893B

RESPONSE CURVE  
refer to page 16

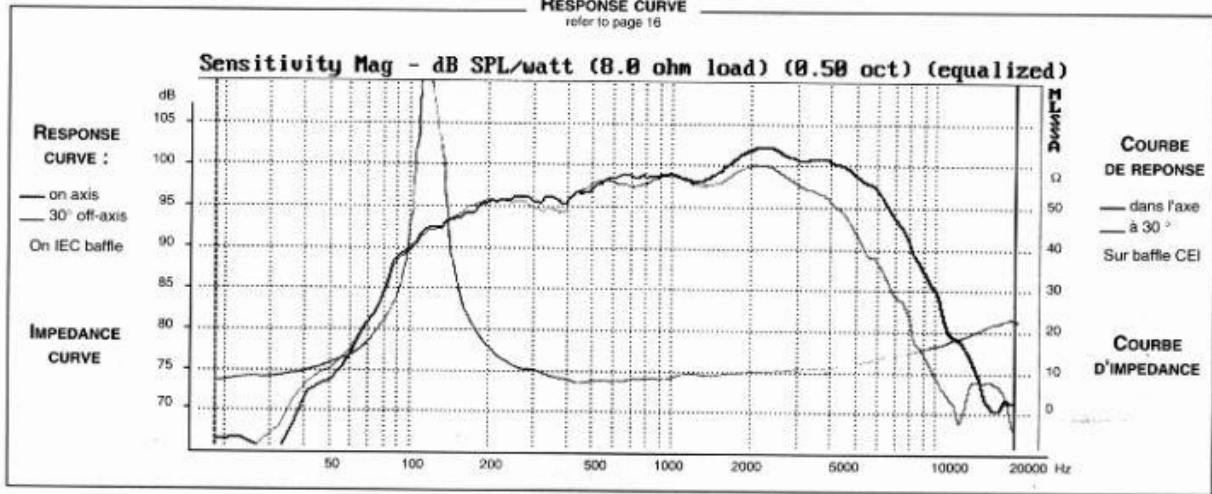

### SPECIFICATIONS

Technical Characteristics	Symbol	Value	Units
<b>PRIMARY APPLICATION</b>			
Nominal Impedance	Z	8	Ω
Resonance Frequency	F <sub>s</sub>	134	Hz
Nominal Power Handling	P	100	W
Sensitivity	E	101	dB
<b>VOICE COIL</b>			
Voice coil diameter	∅	40	mm
Minimum Impedance	Z <sub>min</sub>	6,5	Ω
DC Resistance	R <sub>e</sub>	6,3	Ω
Voice Coil Inductance	L <sub>bm</sub>	0,12	mH
Voice coil Length	h	7	mm
Former	-	Kapton	-
Number of layers	n	1	-
<b>MAGNET</b>			
Magnet dimensions	∅ x h	120x20	mm
Magnet weight	m	0,88	kg
Flux density	B	1,4	T
Force factor	BL	7,06	NA <sup>-1</sup>
Height of magnetic gap	H <sub>e</sub>	6	mm
Stray flux	F <sub>mag</sub>	-	Am <sup>2</sup>
Linear excursion	X <sub>max</sub>	±0,5	mm
<b>PARAMETERS</b>			
Suspension Compliance	C <sub>ms</sub>	0,22 · 10 <sup>-3</sup>	mN <sup>-1</sup>
Mechanical Q Factor	Q <sub>ms</sub>	5,79	-
Electrical Q Factor	Q <sub>es</sub>	0,68	-
Total Q Factor	Q <sub>ts</sub>	0,60	-
Mechanical Resistance	R <sub>ms</sub>	0,93	kg s <sup>-1</sup>
Moving Mass	M <sub>ms</sub>	6,4 · 10 <sup>-3</sup>	kg
Effective Piston Area	S	1,39 · 10 <sup>-2</sup>	m <sup>2</sup>
Volume Equivalent of Air at Cas	V <sub>as</sub>	6,05 · 10 <sup>-2</sup>	m <sup>3</sup>
Mass of speaker	M	2,6	kg

### APPLICATION PARAMETERS

Symbol	Description	Unit
F <sub>c</sub>	Crossover Frequency	Hz
S	Slope	dB / Oct.
L	Self-inductance	mH
C	Capacitor	μF
P	Nominal Power Handling	W

IMPULSE RESPONSE

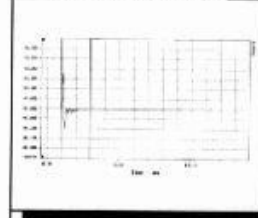

WATERFALL  
refer to page 16

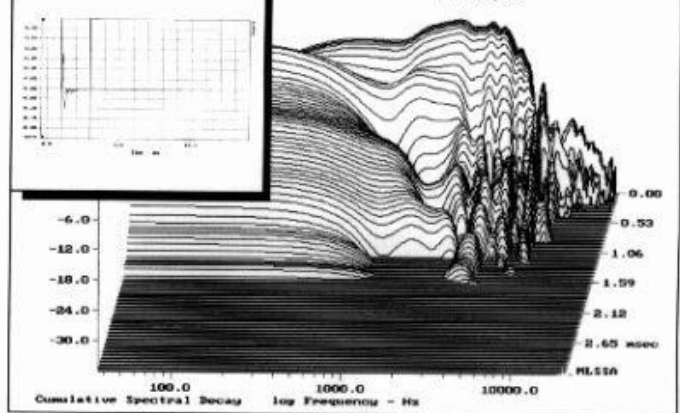

SUGGESTED APPLICATIONS  
refer to page 6 to 13

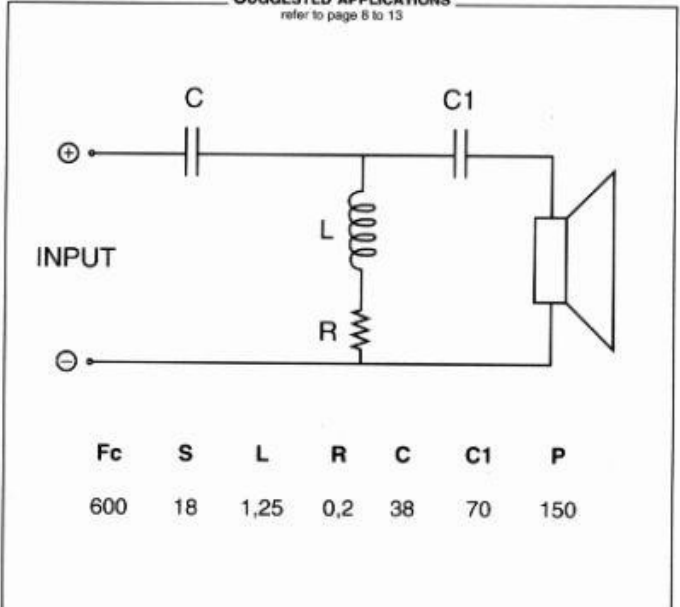

Please refer to method of measurement and measurement conditions pages 15 to 19.  
 Audax may, without prior notification modify the specifications on its products further to research and development requirements.