

Micro 10 mm Neodymium GOLD DOME

Ion deposited pure gold
 Ultra compact (ø 29,5mm)
 Ultra-light weight (10g)
 Balanced drive concept design*
 Ferrofluid - cooled voice coil
 Extended frequency response
 Ultra-light moving parts
 Encapsulated neodymium magnet

Or pur déposé sous vide
 Ultra compact (ø 29,5mm)
 Ultra léger (10g)
 Concept balanced drive*
 Bobine refroidie par ferrofluide
 Bande passante étendue
 Equipage mobile ultra léger
 Aimant néodyme surmoulé

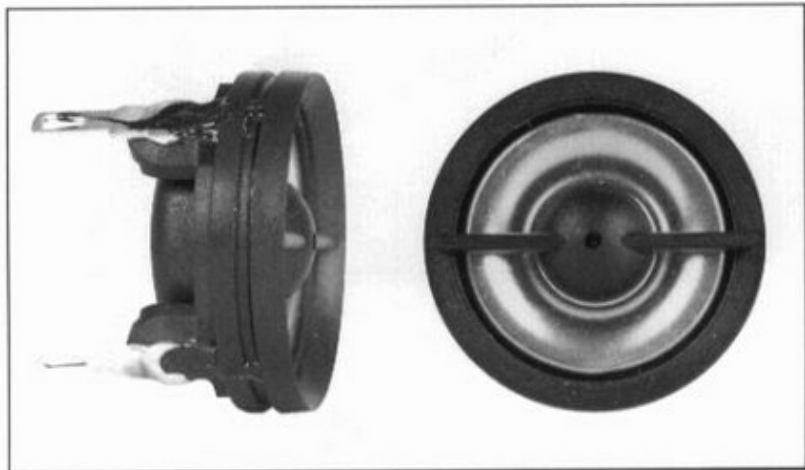

Keeping the performance of the well-known Audax 10 mm tweeters while reducing size to the extreme can be quite a challenge. It is however achieved with the new Micro 10 tweeter, a combination of proven Audax know-how and latest technologies : high precision magnet system, rare earth magnet (neodymium-iron-boron), pure (24 carats) gold ion deposit adding stiffness, damping and high frequencies definition, ultra light moving parts with formeless voice coil piston area equally divided between dome and active suspension ("balanced drive" concept). Its amazing size (<10cc) and weight (10 g) without compromise on performance make it an ideal choice for a growing number of applications where these factors are essential : automotive, multimedias, telecommunications, HDTV and home theaters. A special bezel has been designed to provide easy mounting of this tweeter into compact Hi-Fi systems (refer to page 265). Easily coupled with 1st order crossover as shown in Fig. 1 or with 2nd order for increased power handling.

Aboutissement d'une miniaturisation poussée, tout en conservant les performances de tweeters 5 fois plus lourds, ce tweeter à dôme de 10 mm bénéficie des technologies les plus récentes : usinage de précision du système magnétique, aimant terres rares (néodyme-fer-bore), dépôt sous vide d'or pur (24 carats) pour améliorer la définition dans le haut du spectre. Il doit l'extrême légèreté de son équipement mobile à sa bobine sans support. La surface émissive est équilibrée entre le dôme et la suspension active, son extrême compacité (<10cm³) et son poids plume (10 g) en font un "must" pour les applications de plus en plus nombreuses où encombrement et poids sont des facteurs déterminants : automobile, système multimédia, télécommunications, TVHD, haute fidélité compacte. Une pièce spécifique a été conçue afin de permettre un montage aisé de ce tweeter dans une enceinte Hi Fi (voir page 265). Il peut être filtré au premier ordre comme proposé sur le schéma Fig. 1 ou au 2ème ordre pour une augmentation de la tenue en puissance.

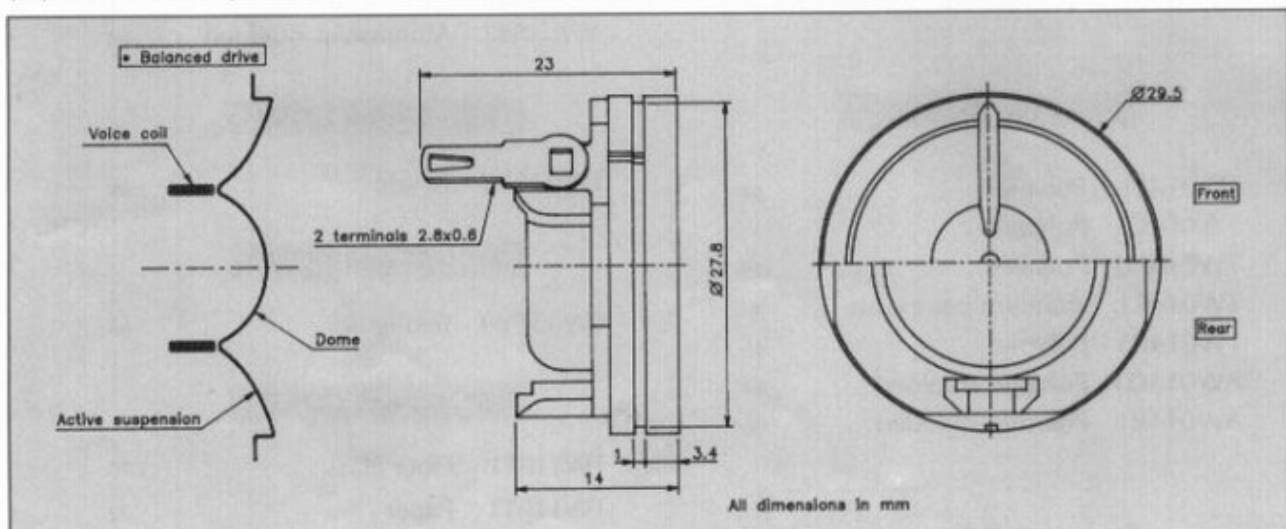

RESPONSE CURVE
refer to page 16

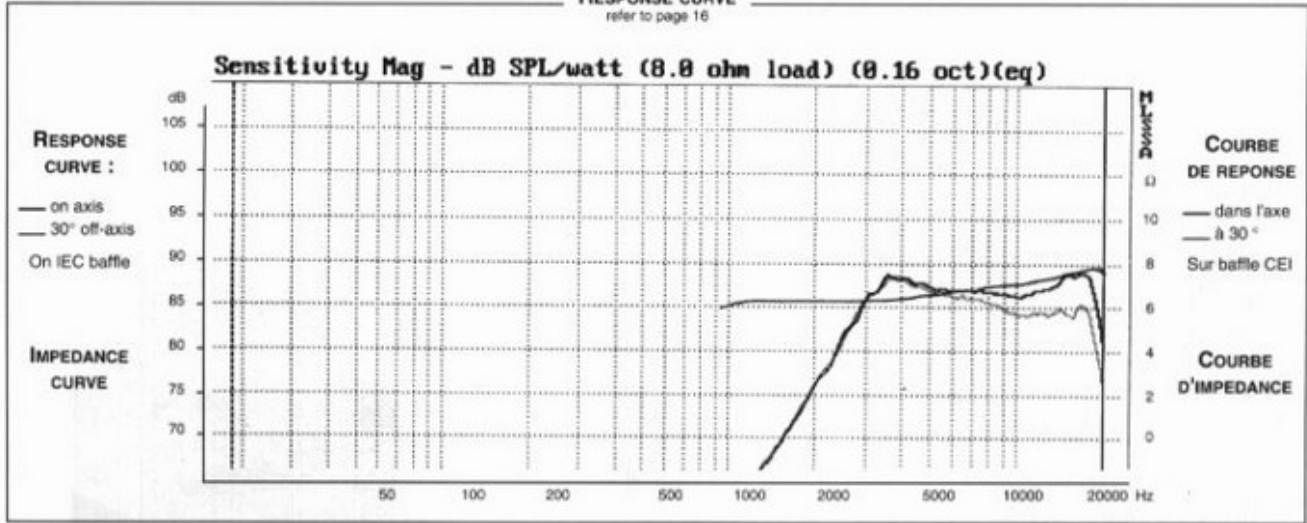

SPECIFICATIONS

Technical Characteristics	Symbol	Value	Units
PRIMARY APPLICATION			
Nominal Impedance	Z	8	Ω
Resonance Frequency	Fs	3000	Hz
Nominal Power Handling	P	25	W
Sensitivity	E	87	dB
VOICE COIL			
Voice coil diameter	Ø	10	mm
Minimum Impedance	Zmin	6,4	Ω
DC Resistance	Re	5,5	Ω
Voice Coil Inductance	Lbm	32	µH
Voice coil Length	h	2	mm
Former	-	-	-
Number of layers	n	2	-
MAGNET			
Magnet dimensions	Ø x h	9,5 x 2	mm
Magnet weight	m	-	kg
Flux density	B	1	T
Force factor	BL	1,1	NA ⁻¹
Height of magnetic gap	He	2	mm
Stray flux	Fmag	1,2	Am ⁻¹
Linear excursion	Xmax	±0,25	mm
PARAMETERS			
Suspension Compliance	Cms	-	mN ⁻¹
Mechanical Q Factor	Qms	-	-
Electrical Q Factor	Qes	-	-
Total Q Factor	Qts	-	-
Mechanical Resistance	Rms	-	kg s ⁻¹
Moving Mass	Mms	0,11.10 ⁻³	kg
Effective Piston Area	S	3,14.10 ⁻⁴	m ²
Volume Equivalent of Air at Cas	Vas	-	m ³
Mass of speaker	M	0,01	kg

APPLICATION PARAMETERS

Symbol	Description	Unit
Fc	Crossover Frequency	Hz
S	Slope	dB / Oct
L	Self-inductance	mH
C	Capacitor	µF
P	Nominal Power Handling	W

IMPULSE RESPONSE

WATERFALL
refer to page 16

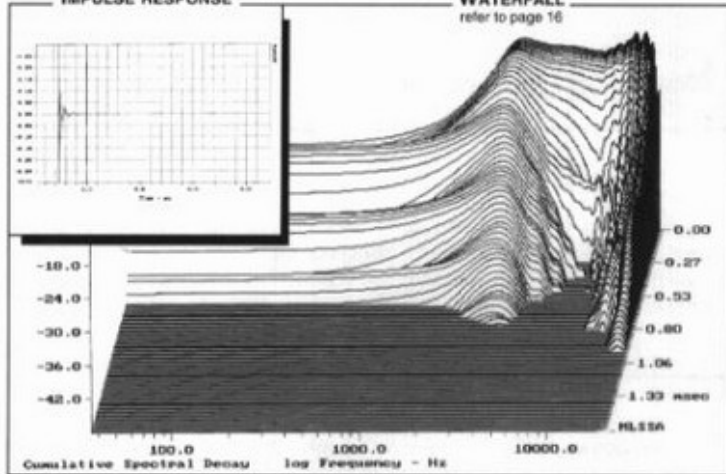

SUGGESTED APPLICATIONS
refer to page 6 to 13

