

AUDAX

LA PASSION DU HAUT-PARLEUR

TW010F1

TWEETER

100861P

10 mm POLYMER DOME

Balanced drive concept design*
Ferrofluid - cooled voice coil
Extended frequency response
Ultra-light moving parts
Encapsulated magnet assembly

Concept *balanced drive**
Bobine refroidie par ferrofluide
Bande passante étendue
Equipage mobile ultra léger
Ensemble magnétique surmoulé

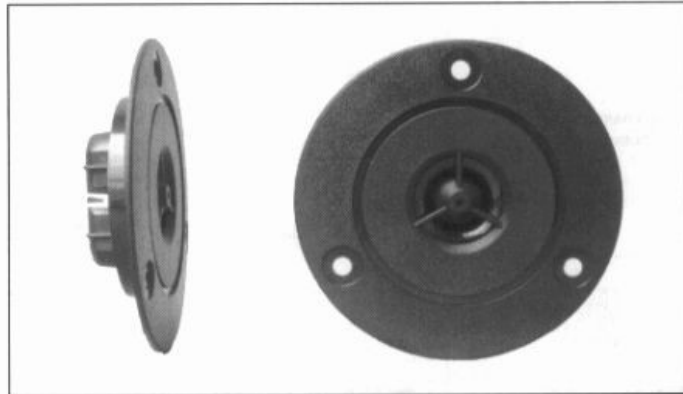

Very compact, 10 mm polymer dome tweeter. Ultra light moving parts, formerless voice coil. Piston area equally composed of dome and active suspension (Balanced drive concept). Offers the Audiophile a combination of musical qualities : Spatial dispersion, exceptional transient response, high harmonics reproduction. Easily coupled with 1st order crossover as shown in Fig 1 or with 2nd order for increased power handling.

Très compact, ce tweeter à dôme de 10 mm en polymère doit l'extrême légèreté de son équipement mobile à sa bobine sans support. La surface émissive est équilibrée entre le dôme et la suspension active. Il offre à l'audiophile une conjugaison de performances musicales : dispersion spatiale, réponse impulsionnelle, reproduction des harmoniques supérieurs. Il peut être filtré au premier ordre comme proposé sur le schéma Fig 1 ou au 2ème ordre pour une augmentation de la tenue en puissance.

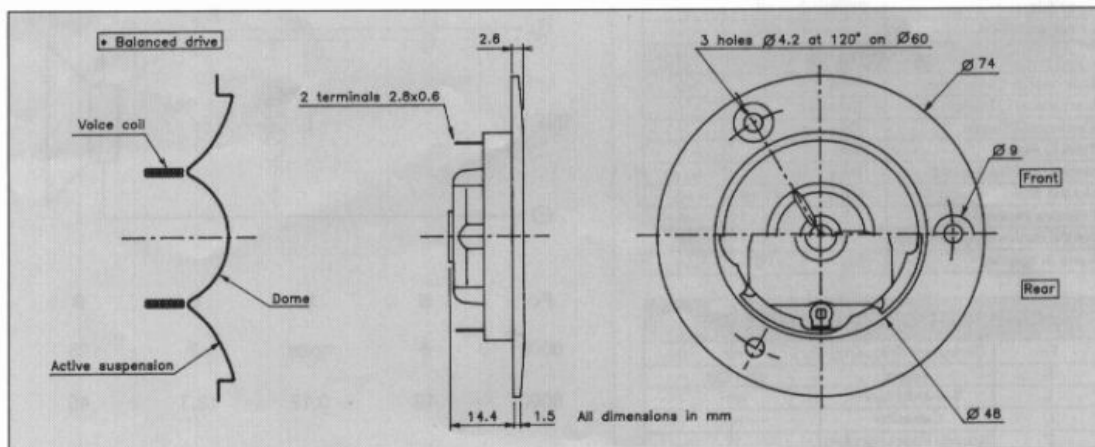

TW010F1 D08YYD0074

100006G

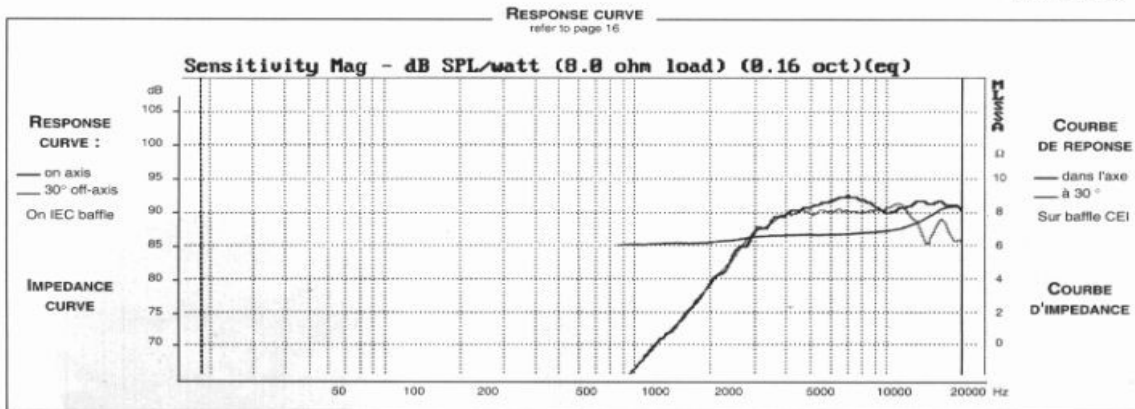

SPECIFICATIONS

Technical Characteristics	Symbol	Value	Units
PRIMARY APPLICATION			
Nominal Impedance	Z	8	Ω
Resonance Frequency	Fs	3000	Hz
Nominal Power Handling	P	25	W
Sensitivity	E	90	dB

VOICE COIL			
Voice coil diameter	Ø	10	mm
Minimum Impedance	Zmin	6,4	Ω
DC Resistance	Re	5,5	Ω
Voice Coil Inductance	Lbm	32	µH
Voice coil Length	h	2	mm
Former	-	-	-
Number of layers	n	2	-

MAGNET			
Magnet dimensions	Ø x h	29 x 5	mm
Magnet weight	m	0,017	kg
Flux density	B	1,1	T
Force factor	BL	1,3	NA ⁻¹
Height of magnetic gap	He	1,5	mm
Stray flux	Fmag	15	Am ⁻¹
Linear excursion	Xmax	±0,25	mm

PARAMETERS			
Suspension Compliance	Cms	-	mN ⁻¹
Mechanical Q Factor	Qms	-	-
Electrical Q Factor	Qes	-	-
Total Q Factor	Qts	-	-
Mechanical Resistance	Rms	-	kg s ⁻¹
Moving Mass	Mms	0,11.10 ⁻³	kg
Effective Piston Area	S	3,14.10 ⁻⁴	m ²
Volume Equivalent of Air at Cas	Vas	-	m ³
Mass of speaker	M	0,055	kg

APPLICATION PARAMETERS

Fc	Crossover Frequency	Hz
S	Slope	dB / Oct.
L	Self-inductance	mH
C	Capacitor	µF
P	Nominal Power Handling	W

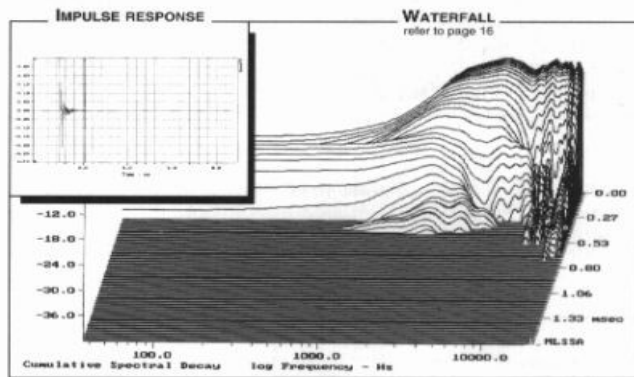

SUGGESTED APPLICATIONS
refer to page 8 to 13

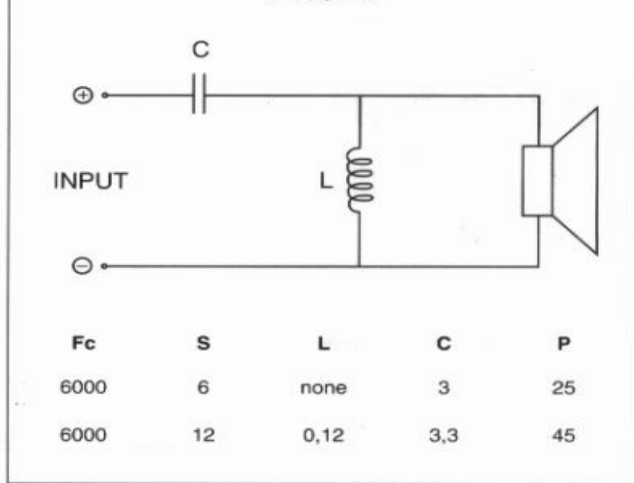

Please refer to method of measurement and measurement conditions pages 15 to 19.
Audax may, without prior notification modify the specifications on its products further to research and development requirements.