

AUDAX

LA PASSION DU HAUT-PARLEUR

TW010P1

TWEETER

100779X

10 mm POLYMER DOME

4 Ω

CAR LINE

Hi Fi automotive specific design
Balanced drive concept design*
Ferrofluid - cooled voice coil
Extended frequency response
Ultra-light moving parts
Encapsulated magnet assembly

Application Hi Fi automobile
Concept *balanced drive**
Bobine refroidie par ferrofluide
Bande passante étendue
Equipage mobile ultra léger
Ensemble magnétique surmoulé

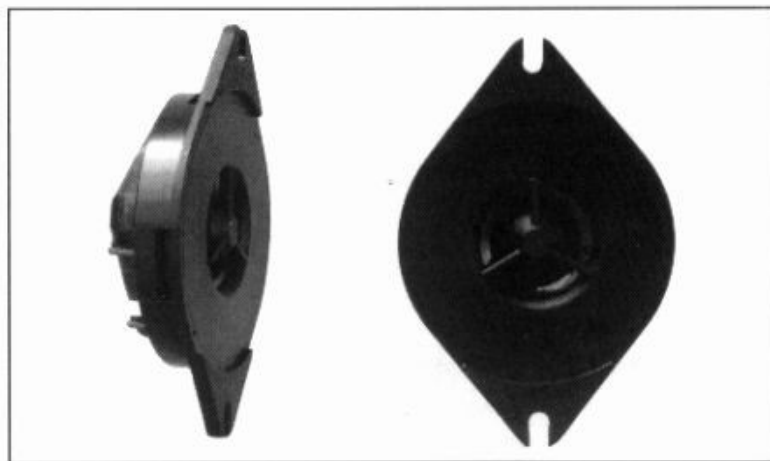

Very compact, 10 mm polymer dome tweeter. Ultra light moving parts, formerless voice coil. Piston area equally composed of dome and active suspension (Balanced drive concept). Offers the Audiophile a combination of musical qualities : Spatial dispersion, exceptional transient response, high harmonics reproduction. Specifically designed for use in a 2 or 3 way Hi Fi system in the automotive environment. Easily coupled with 1st order crossover as shown in Fig 1 or with 2nd order for increased power handling.

Très compact, ce tweeter à dôme de 10 mm en polymère doit l'extrême légèreté de son équipage mobile à sa bobine sans support. La surface émissive est équilibrée entre le dôme et la suspension active. Il offre à l'audiophile une conjugaison de performances musicales : dispersion spatiale, réponse impulsionnelle, reproduction des harmoniques supérieurs. Sa configuration le destine plus particulièrement au secteur automobile (tableau de bord, portières, ...) en complément d'un ensemble haute fidélité 2 ou 3 voies. Il peut être filtré au premier ordre comme proposé sur le schéma Fig 1 ou au 2ème ordre pour une augmentation de la tenue en puissance.

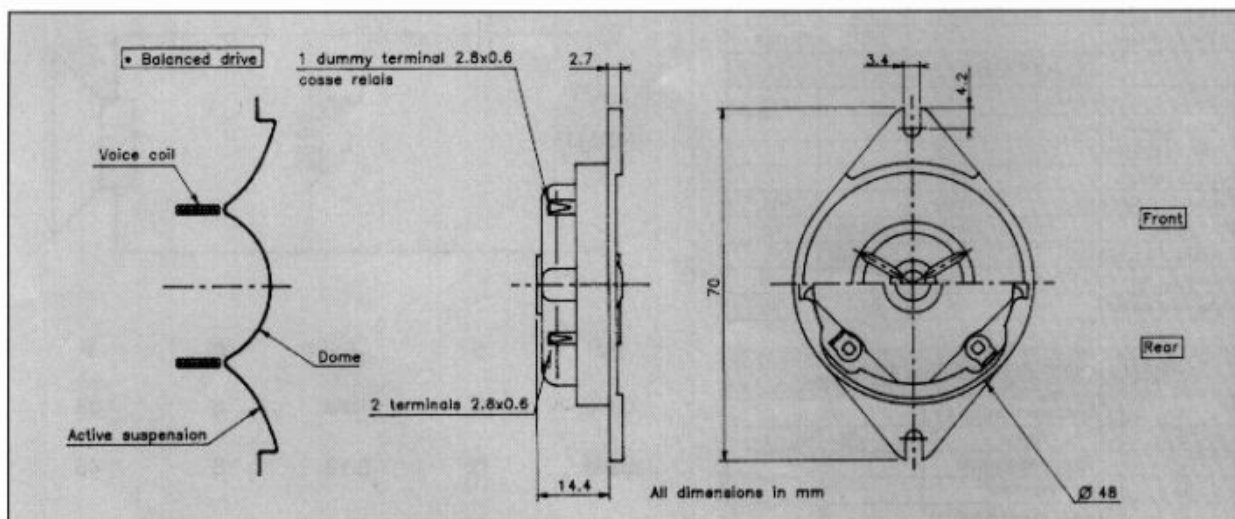

RESPONSE CURVE
 refer to page 15

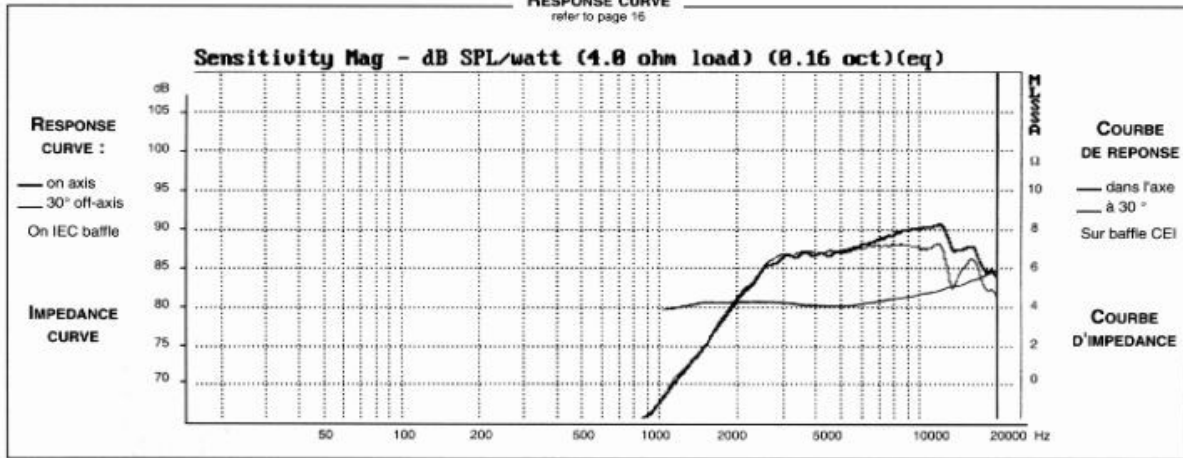

SPECIFICATIONS

Technical Characteristics	Symbol	Value	Units
---------------------------	--------	-------	-------

PRIMARY APPLICATION

Nominal Impedance	Z	4	Ω
Resonance Frequency	Fs	3000	Hz
Nominal Power Handling	P	25	W
Sensitivity	E	88	dB

VOICE COIL

Voice coil diameter	\varnothing	10	mm
Minimum Impedance	Zmin	4,3	Ω
DC Resistance	Re	3,4	Ω
Voice Coil Inductance	Lbm	25	μ H
Voice coil Length	h	2	mm
Former	-	-	-
Number of layers	n	2	-

MAGNET

Magnet dimensions	$\varnothing \times h$	29 X 5	mm
Magnet weight	m	0,17	kg
Flux density	B	1,1	T
Force factor	BL	1,1	NA ⁻¹
Height of magnetic gap	He	1,5	mm
Stray flux	Fmag	15	Am ⁻¹
Linear excursion	Xmax	$\pm 0,25$	mm

PARAMETERS

Suspension Compliance	Cms	-	mN ⁻¹
Mechanical Q Factor	Qms	-	-
Electrical Q Factor	Qes	-	-
Total Q Factor	Qts	-	-
Mechanical Resistance	Rms	-	kg s ⁻¹
Moving Mass	Mms	0,13.10 ⁻¹	kg
Effective Piston Area	S	3,14.10 ⁻¹	m ²
Volume Equivalent of Air at Cas	Vas	-	m ³
Mass of speaker	M	0,50	kg

APPLICATION PARAMETERS

Fc	Crossover Frequency	Hz
S	Slope	dB / Oct.
L	Self-inductance	mH
C	Capacitor	μ F
P	Nominal Power Handling	W

IMPULSE RESPONSE

WATERFALL
 refer to page 16

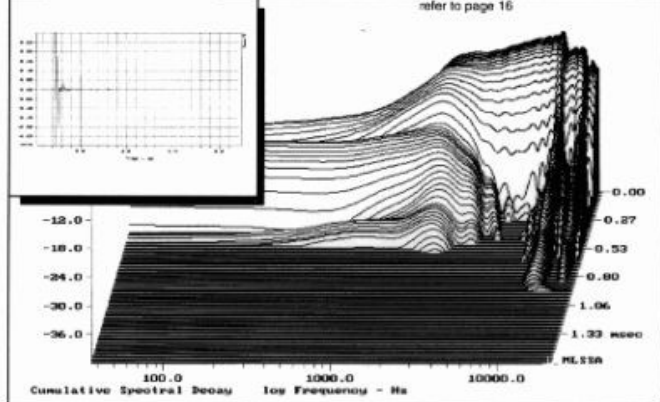

SUGGESTED APPLICATIONS
 refer to page 8 to 13

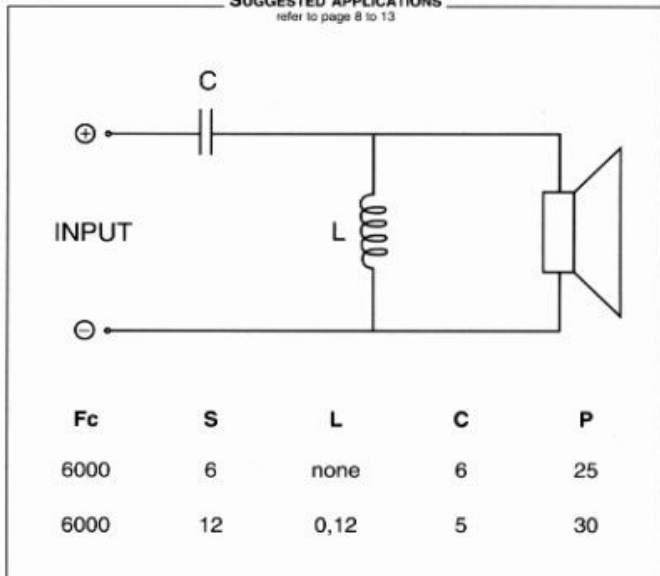

Please refer to method of measurement and measurement conditions pages 15 to 19.

Audax may, without prior notification modify the specifications on its products further to research and development requirements.