

AUDAX
LA PASSION DU HAUT-PARLEUR

VE170F8

BASS MIDRANGE

100930M

6 1/2" - FIBERGLASS CONE DRIVER - 170 mm

4 Ω

CAR LINE

Hi Fi automotive application
Extended frequency response
Woven fiberglass cone
High loss rubber surround
Linear frequency response
Stamped steel chassis

Application Hi Fi automobile
Réponse étendue
Cône fibre de verre tissée
Suspension caoutchouc amortissant
Courbe de réponse linéaire
Châssis acier embouti



This 6 1/2" Bass-Midrange driver is specifically designed for Hi Fi automotive application (4 Ω). A woven fiberglass cone coupled with a high loss rubber surround suspension combine excellent sonic qualities and long term reliability in automotive environment. It offers a largemagnet for high efficiency and high temperature voice coil for good power handling. The "suggested applications" charts indicate various driver loads. The response curves shown on the diagram indicate the predicted low end response of the driver in the suggested box volume (Vb) with suggested port (Dp-Lp).

Ce Boomer-Médium de 170 mm est particulièrement destiné à des applications Hi Fi automobile (4Ω). Sa membrane en fibre de verre tissée associée à une suspension en toile caoutchoutée offre d'excellentes qualités sonores ainsi qu'une fiabilité exceptionnelle dans un environnement automobile. Une structure magnétique largement dimensionnée lui procure un rendement élevé et une bobine haute température, sa bonne tenue en puissance. Le tableau "Suggested applications" indique différents types de charge. Les courbes publiées correspondent à la réponse dans le grave pour un volume (Vb) et une dimension d'évent donnée (Dp-Lp).

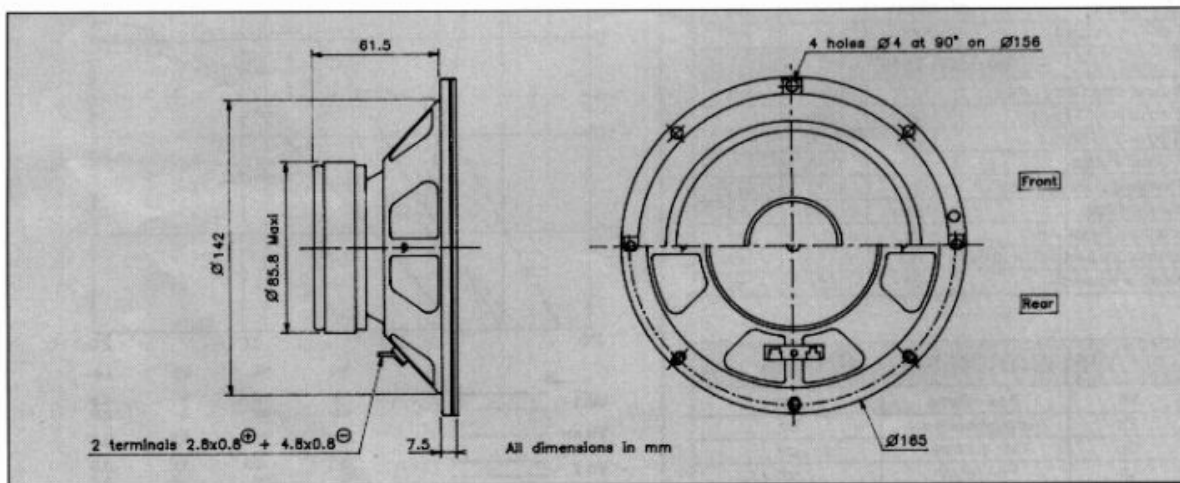

VE170F8 W04FGS2513

100966V

AUDAX

LA PASSION DU HAUT-PARLEUR

VE170F8

BASS MIDRANGE

RESPONSE CURVE
refer to page 16

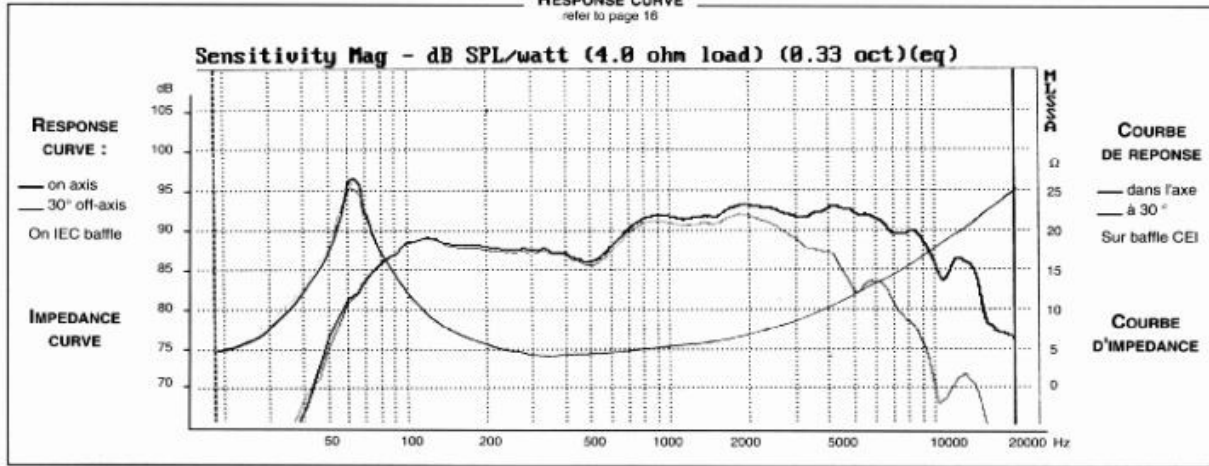

SPECIFICATIONS

Technical Characteristics	Symbol	Value	Units
PRIMARY APPLICATION			
Nominal Impedance	Z	4	Ω
Resonance Frequency	Fs	56	Hz
Nominal Power Handling	P	50	W
Sensitivity	E	90	dB

VOICE COIL			
Voice coil diameter	\varnothing	25	mm
Minimum Impedance	Zmin	4,8	Ω
DC Resistance	Re	3,7	Ω
Voice Coil Inductance	Lbm	0,01	mH
Voice coil Length	h	7	mm
Former	-	Aluminium	-
Number of layers	n	2	-

MAGNET			
Magnet dimensions	$\varnothing \times h$	84 x 15	mm
Magnet weight	m	0,345	kg
Flux density	B	1,1	T
Force factor	BL	5,62	NA ⁻¹
Height of magnetic gap	He	5	mm
Stray flux	Fmag	-	Am ⁻¹
Linear excursion	Xmax	± 1	mm

PARAMETERS			
Suspension Compliance	Cms	$0,63 \cdot 10^{-3}$	mN ⁻¹
Mechanical Q Factor	Qms	3,14	-
Electrical Q Factor	Qes	0,53	-
Total Q Factor	Qts	0,45	-
Mechanical Resistance	Rms	1,46	kg s ⁻¹
Moving Mass	Mms	$13 \cdot 10^{-3}$	kg
Effective Piston Area	S	$142 \cdot 10^{-2}$	m ²
Volume Equivalent of Air at Cas	Vas	$18 \cdot 10^{-3}$	m ³
Mass of speaker	M	0,92	kg

APPLICATION PARAMETERS

Symbol	Description	Unit
Vb	Box volume	dm ³
Fb	Tuning frequency	Hz
Dp	Port diameter	cm
Lp	Port length	cm

IMPULSE RESPONSE WATERFALL
refer to page 16

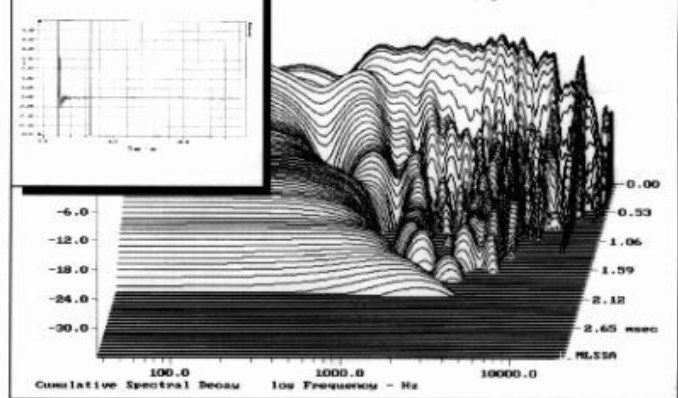

SUGGESTED APPLICATIONS
refer to page 8 to 13

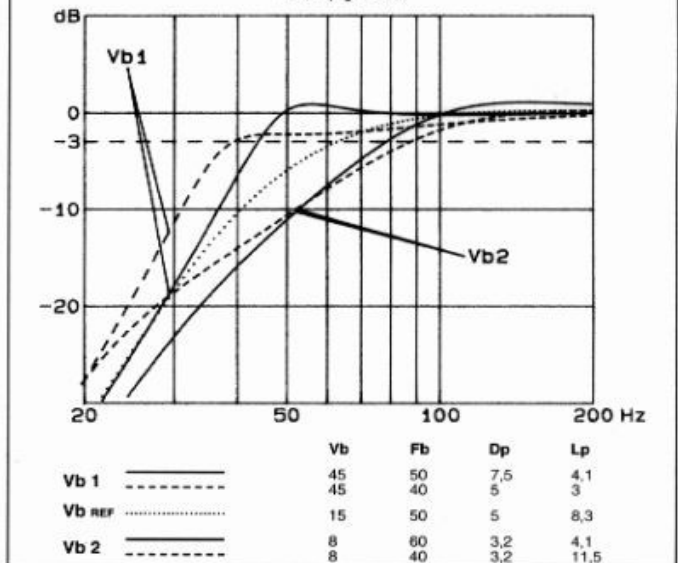

Please refer to method of measurement and measurement conditions pages 15 to 19.
Audax may, without prior notification modify the specifications on its products further to research and development requirements.