



ET 448

Elite Tweeter, Ø 72mm, 8Ω



Features:

- * 72mm IDR™ Improved Dispersion Recess design aluminum face plate
- * Large Hexatech™ aluminum voice coil
- * Replaceable dome / coil assembly
- * Double Neodymium magnet system
- * Ferro fluid cooled
- * High power handling

SPECIFICATIONS

General Data

Overall Dimensions	DxH	72mm(2.83")x58mm(2.28")
Nominal Power Handling (DIN)	P	120W
Transient Power 10ms		1000W
Sensitivity 1W/1M		92dB SPL
Frequency Response		2,200-22,000 Hz
Cone/Dome Material		Acuflex™ hand coated soft dome
Net Weight	Kg	0.102

Electrical Data

Nominal Impedance	Z	8Ω
DC Resistance	Re	5.2Ω
Voice Coil Inductance @ 1KHz	LBM	0.05mH

Voice Coil and Magnet Parameters

Voice Coil Diameter	DIA	28mm
Voice Coil Height		2.7mm
HE Magnetic Gap Height	HE	2.5mm
Max. Linear Excursion	X	
Voice Coil Former		Aluminum
Voice Coil Wire		Hexatech™ Aluminum
Number Of Layers		2
Magnet System Type		Double Neodymium
B Flux Density	B	1.6 T
BL Product	BXL	2.3 N.A

T-S Parameters

Suspension Compliance	Cms	
Mechanical Q Factor	Qms	
Electrical Q Factor	Qes	
Total Q Factor	Qts	
Mechanical Resistance	Rms	
Moving Mass	Mms	0.44 g
Eq. Gas Air Load (liters)	VAS	
Resonant Frequency	Fs	750 Hz 10%
Effective Piston Area	SD	6.0 cm ²

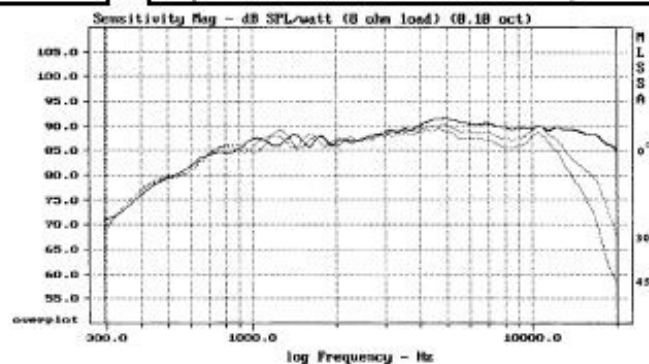
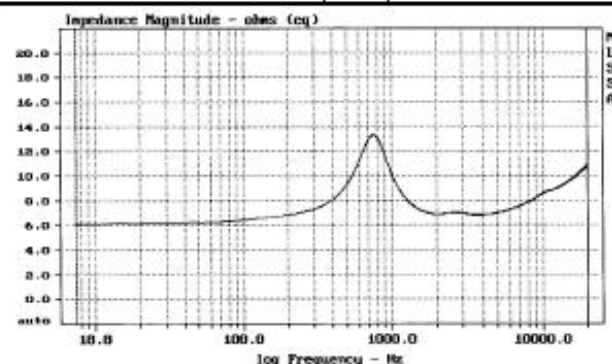
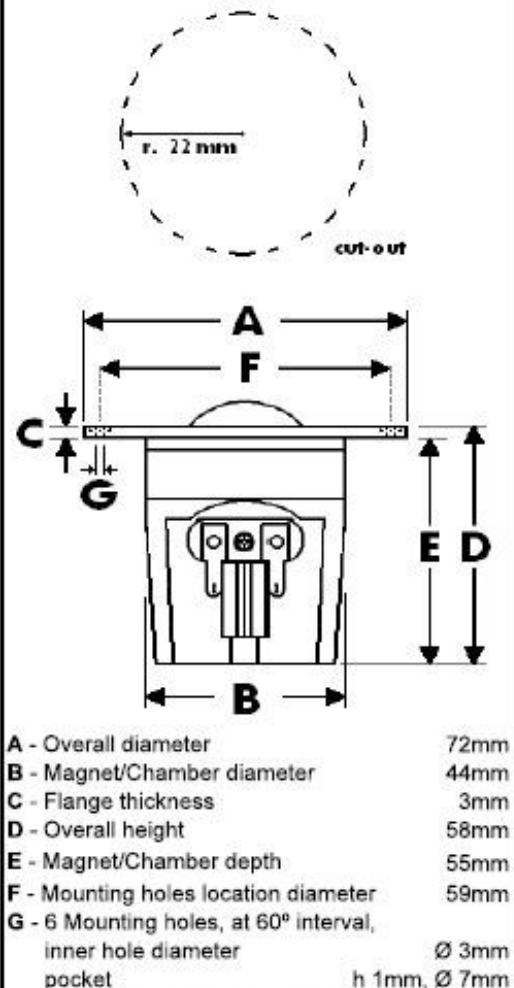

This model replaces former Morel MDT-44 model.

Morel operate policy of continuous product design improvement, consequently specifications are subject to alteration without prior notice.