

HIF 13 H 2 CA 12

13 cm - 5"

BASS MIDRANGE

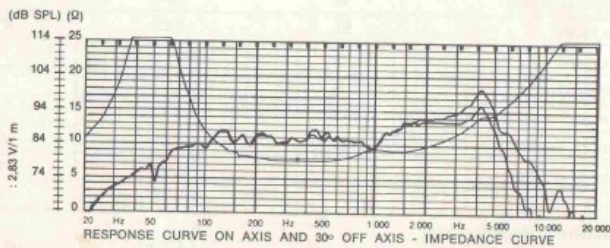
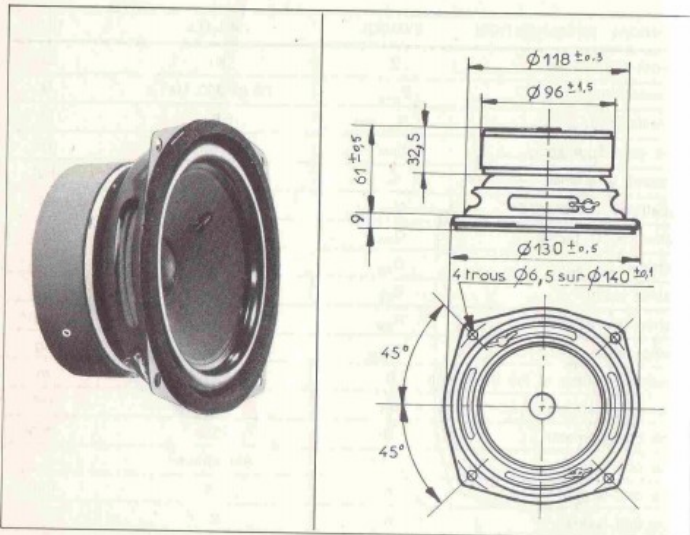

Same characteristics as HIF 13 F-2 CA 12.
Also available with cosmetic ring. Reference:
HIF 13 H-C-2 CA 12.

HIF 13 H 2 CA 12

13 cm - 5"

TECHNICAL SPECIFICATION	SYMBOL	VALUE	UNIT
Nominal impedance	Z	8	Ω
Minimum impedance	Z _{min}	7,5 @ 300 Hz	Ω
DC resistance	R _{sec}	6,8	Ω
Voice coil inductance	L _{BM}	625	μH
Resonant frequency	f _s	42 ± 6	Hz
Suspension compliance	C _{MB}	1,5 · 10 ⁻³	mN ⁻¹
Mechanical Q factor	Q _{MS}	2,55	
Electrical Q factor	Q _{ES}	0,33	
Total Q factor	Q _{TS}	0,29	
Mechanical resistance	R _{MS}	1	kg s ⁻¹
Moving mass	M _{MD}	9,7 · 10 ⁻³	kg
Emissive diameter of the diaphragm	D	0,104	m
Effective piston area	S _D	0,0084	m ²
Voice coil diameter	d	25,5	mm
Voice coil former		Aluminium	
Voice coil length	h	12	mm
Voice coil layers	n	2	
Flux density	B	1,53	T
Flux in the Gap	∅	0,490 · 10 ⁻³	Wb
Magnetic energy	W	0,368	Ws
Force factor	BL	7,32	NA ⁻¹
Gap volume	V _E	0,395 · 10 ⁻⁶	m ³
Height of the Gap	H _E	4	mm
Diameter of the magnet	∅ A	96	mm
Height of magnet	B	25	mm
Weight of magnet		0,725	kg
Mass of speaker		1,345	kg
Characteristic efficiency level :			
1 W, pink noise, weighted	η	87 (W)	dB SPL
Nominal power handling		30	W
Acceleration factor	Γ	755	ms ⁻² A ⁻¹