

## Model B110. Specification Number SP1003

Compact, long throw bass/mid range unit, suitable for use in either a compact full range system, or as a specialised mid range unit in a multi-way system.

**Net weight:** 1.13 kg (2.5 lb)

**Nominal impedance:** 8Ω

**Nominal frequency range:** 55-3,500 Hz

**Typical enclosure volumes:**

Totally enclosed box 5-10 litres (0.2-0.4 cu ft)

MF enclosure 4 litres (0.15 cu ft)

**Power handling:**

Continuous sine wave 15 V RMS (see note 1)

Programme full range 30 W (see note 2)

Programme mid range only 80 W (see note 2)

**Magnet:**

Flux density 1.0 T (11,000 gauss)

Total flux  $5.8 \times 10^{-4}$  Wb (58,000 Maxwells)

**Sensitivity:** Pink noise input for 96 dB SPL at  
1 metre on axis 12.5 V RMS

**Voice coil:**

Diameter 26 mm (1 in)

Inductance 0.45 mH

Max continuous service temperature (30 min) 180°C

Max intermittent temperature (5 sec) 250°C

Thermal time constant 4 seconds

Thermal resistivity (temp rise per applied Watt) 7° C/W

Nominal DC Resistance,  $R_{DC}$  7.1Ω (tolerance  $\pm 10\%$ )

Typical production spread  $6.7 \pm 0.2\Omega$  (see note 3)

Minimum impedance (in nominal frequency range)  
7.8Ω at 280 Hz

**Diaphragm:**

Effective area,  $S_D$  92 cm<sup>2</sup> (14 sq in)

Effective moving mass,  $M_D$  10.5 gm (0.37 oz)

Max linear excursion,  $X_D$  6 mm peak-peak ( $\frac{1}{4}$  in)

Max damage limited excursion 12 mm peak-peak ( $\frac{1}{2}$  in)

**Free air resonance frequency,  $f_s$ :**

Nominal 35 Hz (tolerance  $\pm 5$  Hz)

Typical production spread  $38.0 \pm 2.0$  Hz (see note 3)

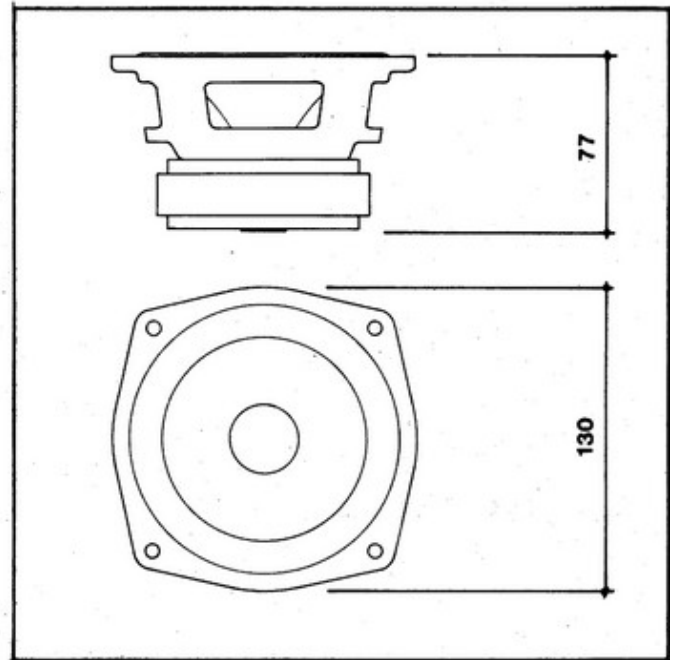

**Total mechanical resistance of suspension,  $R_{MS}$ :**  
0.34 mech Ω

**Suspension compliance,  $C_{MS}$ :**  $2.0 \times 10^{-3}$  m/N  
( $2.0 \times 10^{-6}$  cm/dyne)

**Equivalent volume of compliance,  $V_{AS}$ :** 23.6 litres  
(1,440 cu in)

**Force factor,  $Bl$ :** 7.1 N/A

**Damping:**

Mechanical  $Q_M$  6.7

Electrical  $Q_E$  0.33

Total  $Q_T$  0.31 (see note 4)

### Notes

1 Continuous Power Rating ( $P_c$ ).

$$P_c = \frac{V^2}{R}$$

$V$  is the RMS voltage which can be applied to the unit continuously without thermal overload of the voice coil. At low frequencies the continuous power rating of the speaker may be reduced because of limitations imposed on diaphragm excursion by the acoustic loading.

2 The programme rating of a unit is equal to the maximum programme rating of any system with which the unit may be safely used in conjunction with the recommended dividing network and enclosure.

The programme rating of any system is the undistorted power output of an amplifier with which the system may be satisfactorily operated on normal programme over an extended period of time.

3 "Typical production spread" is derived from statistical analysis of a large number of units, and is calculated to include 95% of all units.

$$4 \quad Q_M = \frac{2\pi f_s M_D}{R_{MS}} \quad Q_E = \frac{2\pi f_s M_D}{(Bl)^2/R_{DC}} \quad \frac{1}{Q_T} = \frac{1}{Q_M} + \frac{1}{Q_E}$$