

Nominal Impedance	Z_n	8	Ω
DC Resistance	R_{dc}	6,8	Ω
Resonant Frequency	f_r	1700	Hz
Power		80	W
Sound Pressure 1W/1m		92	dB SPL
Total Moving Mass	M_{MS}	0,23	g
Effective Piston Area	S_D	6,5	cm ²
Voice Coil Diameter		25	mm
Voice Coil Former		Aluminium	
Voice Coil Length		1,5	mm
Voice Coil Layers		2	
Flux Density	B	1,35	Tesla
Force Factor	B_L	2,4	Tm
Gap Height		2	mm
Magnet Diameter		32	mm
Magnet Height		8	mm
Magnet Weight		0,05	kg
Mass of Speaker		0,07	kg
Dome Material		Fabric	

25 NFA

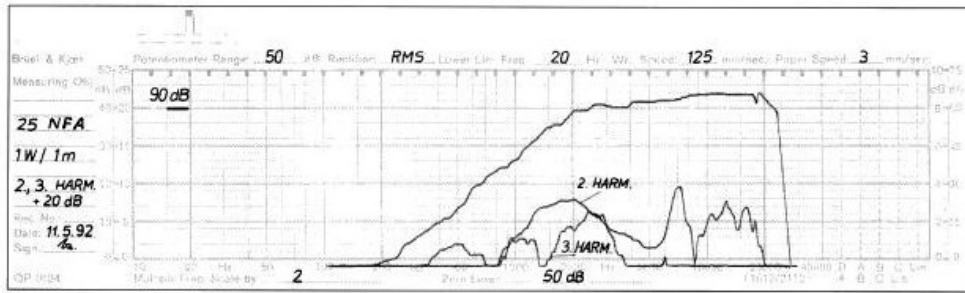

Frequency Response/Distortion

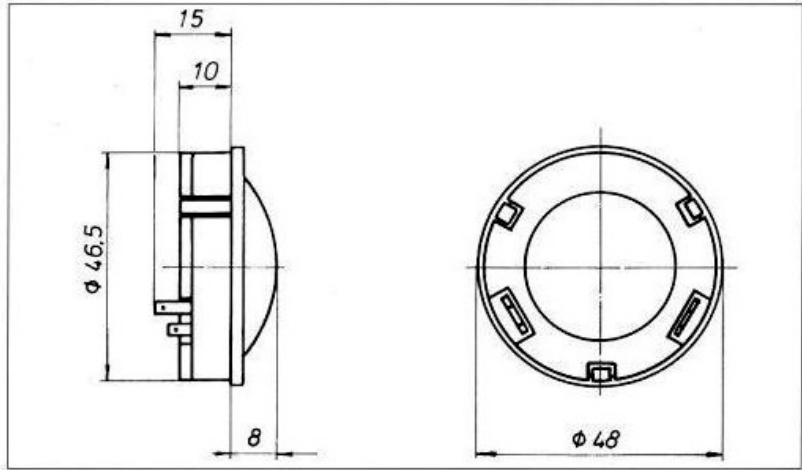
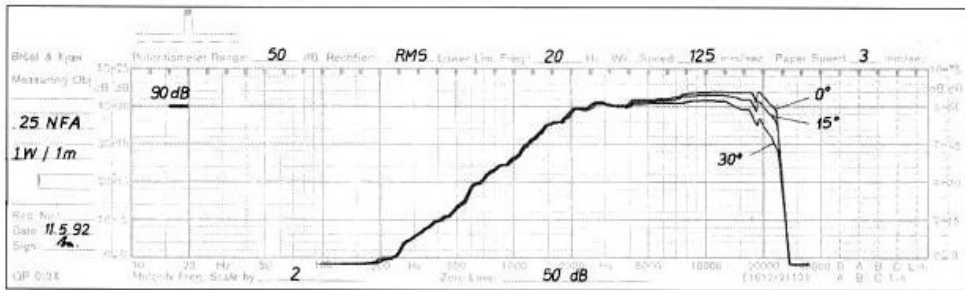

Frequency Response