

# 3/4" DOME TWEETER

# D19TD-05-08

### SPECIAL FEATURES:

- HIGH LOSS DIAPHRAGM
- MAGNETIC FLUID
- HIGH POWER VERSION
- GOOD DISPERSION

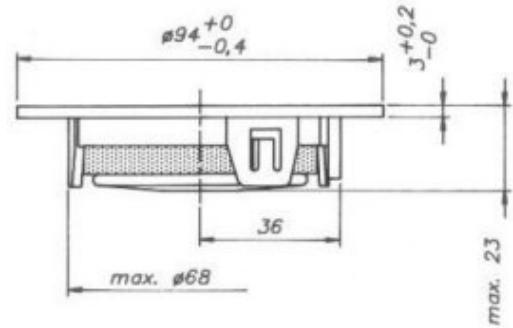

NOMINAL IMPEDANCE	8 Ω
NOMINAL POWER (IEC 268-5)	80 W
FREQUENCY RANGE	3-20 kHz
SENSITIVITY (1W, 1m)	89 dB
EFFECTIVE DIAPHRAGM AREA	4,2 cm <sup>2</sup>
VOICE COIL RESISTANCE	6,2 Ω
OPERATING POWER	5,0 W
VOICE COIL DIAMETER	19 mm
VOICE COIL HEIGHT	1,4 mm
AIR GAP HEIGHT	2 mm
FREE AIR RESONANCE	1700 Hz
MOVING MASS (incl. air)	0,2 g
FORCE FACTOR, B x l	2,6 Txm
MAGNET WEIGHT (3,7 oz)	105 g

