

vifa

M13SG-09-08

Nominal impedance [ohm]	8
Voice coil resistance [ohm]	5.6
Nominal power [W]	35
Short term max power [W]	-
Long term max power [W]	-
Operating power [W]	6.3
Sensitivity [dB]	88
Frequency range [Hz]	54-5000
Free air resonance [Hz]	54
Voice coil diameter [mm]	25
Voice coil height [mm]	10
Air gap height [mm]	6
Voice coil inductance [mH]	0.7
Eff. diaphragm Area [cm ²]	80
Moving mass [g]	6.5
Magnet weight [g]/[oz]	344/12.1
Force factor [Bl]	5.2
VAS [l]	12
Qms	1.50
Qes	0.46
Qts	0.35

OD: 140 mm	CD: 113 mm
FT: 4 mm	ID: 69.6 mm
MD: 93 mm	HD: 4x5@132

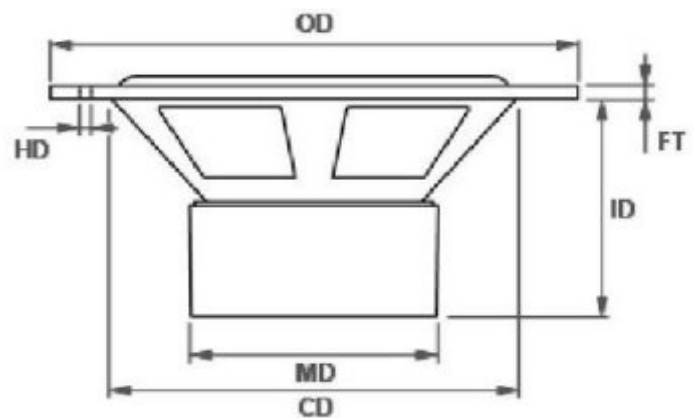

SPL [dB]

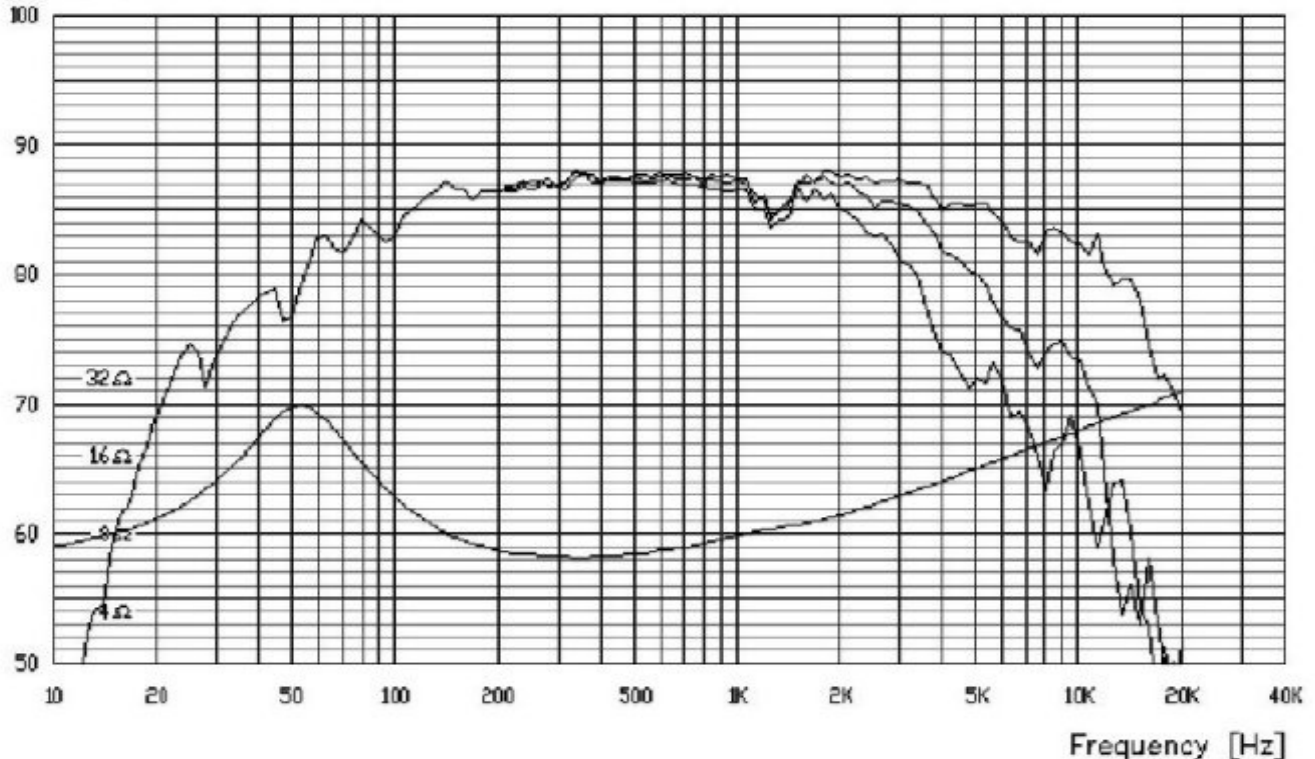

Frequency response: 2.83V / 1m